

Belgrade Portable Cement Silos





Table of Contents

270 Barrel Round Portable Silo	24
350 Barrel Round Portable Silo	26
450 Barrel Round Portable Silo	28
550 Barrel Round Portable Silo	30
700 Barrel Round Portable Silo	32
900 Barrel Round Portable Silo	34
1050 Barrel Round Portable Silo	36
1200 Barrel Round Portable Silo	38
500 Barrel Round Portable Split Silo.....	40
700 Barrel Round Portable Split Silo.....	42
850 Barrel Round Portable Split Silo.....	44
200 Barrel Low Profile Silo.....	46
300 Barrel Low Profile Silo.....	48

270 Barrel Round Portable Silo



270 Barrel Round Portable Silo

- 8'-6" Diameter x 32'-0" Overall Height
- Positive Feed Drive Auger System
- 7" Diameter Screw Conveyor x 17'-0"
- 5 HP Motor and Gear Box Drive
- Heavy Duty Dual Axle Trailer and Tires
- Electric Brakes and Lights Package
- 150 Sq. Ft. Bag Area Dust Collector with Air Vibrator
- Pressure Relief Valve
- Single Speed Trailer Jack
- 13'-6" Auger Discharge Height
- Outside Ladder with OSHA Compliant Fall Arrest Cable System
- 4" Fill Pipe with Aluminum Adapter
- 18" Non-Pressurized Inspection Manhole
- (8) Externally Mounted Air Pads with Manifold, Regulator, and Check Valve
- Sandblast, Prime, and Paint
- Standard Colors:
RAL 7038 Gray, RAL 9010 White,
RAL 1001 Tan, RAL 1032 Yellow

Options

- 225 Sq. Ft. Dust Collector
- 330 Sq. Ft. Pulse Jet Dust Collector
- Bin Level Indicators
- Single Phase Motor
- Hydraulic Drive Motor
- 16 HP Gas Motor
- Motor Starter Controls
- Manual Air Valve Controls
- Upgrade to 9" or 12" Screw Conveyor
- 5" Fill Pipe

Specifications

- Empty Weight 8,500#
- Hitch Weight 1,400#
- 1,080 Cu. Ft. Capacity
- 50 Ton Capacity (Cement)
- Output Capacity Approximately 7 Cu. Ft. Per Minute (7" Screw Conveyor)
- Part Number: BST270P-RD-EB

BELGRADE
STEEL TANK



270 Barrel Round Portable Silo

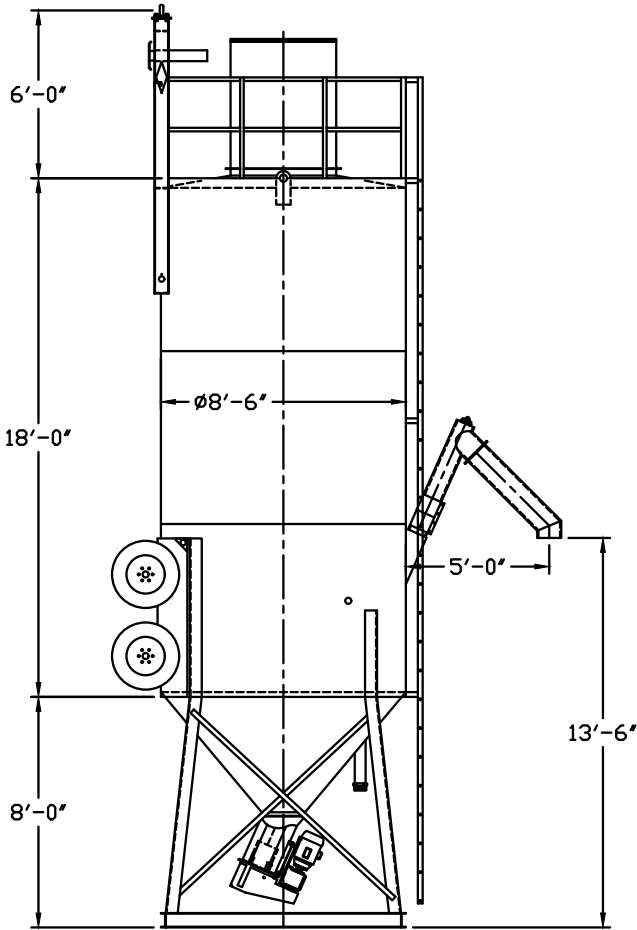

Positive Feed Drive System

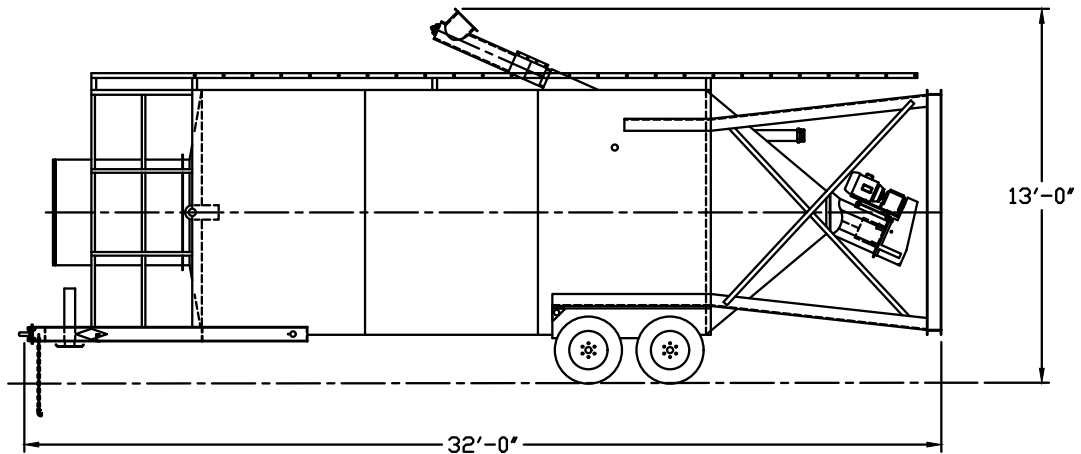
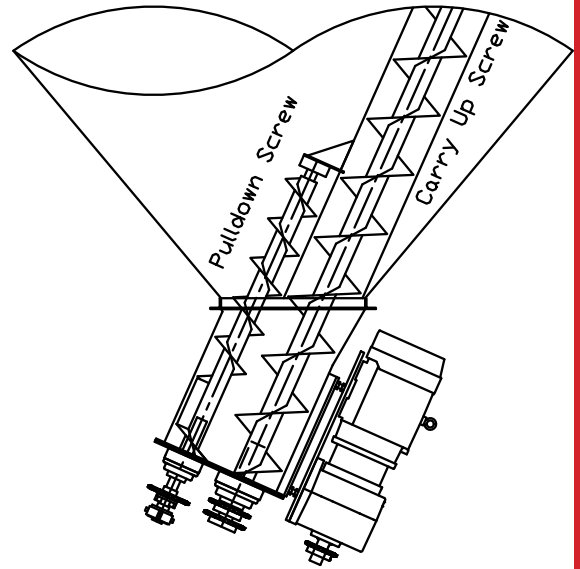

350 Barrel Round Portable Silo



350 Barrel Round Portable Silo

- 8'-6" Diameter x 38'-0" Overall Height
- Positive Feed Drive Auger System
- 9" Diameter Screw x 17'-0"
- 10 HP Motor and Gear Box Drive
- Heavy Duty Dual Axle Trailer and Tires
- Electric Brakes and Lights Package
- 150 Sq. Ft. Bag Area Dust Collector with Air Vibrator
- Pressure Relief Valve
- Single Speed Trailer Jack
- 13'-6" Auger Discharge Height
- Outside Ladder with OSHA Compliant Fall Arrest Cable System
- 4" Fill Pipe with Aluminum Adapter
- 18" Non-Pressurized Inspection Manhole
- (8) Externally Mounted Air Pads with Manifold, Regulator, and Check Valve
- Sandblast, Prime, and Paint
- Standard Colors:
RAL 7038 Gray, RAL 9010 White,
RAL 1001 Tan, RAL 1032 Yellow

Options

- 225 Sq. Ft. Dust Collector
- 330 Sq. Ft. Pulse Jet Dust Collector
- Bin Level Indicators
- Single Phase Motor
- Hydraulic Drive Motor
- Motor Starter Controls
- Manual Air Valve Controls
- Upgrade to 12" Screw Conveyor
- 5" Fill Pipe

Specifications

- Empty Weight 10,000#
- Hitch Weight 2,100#
- 1,400 Cu. Ft. Capacity
- 65 Ton Capacity (Cement)
- Output Capacity Approximately 15 Cu. Ft. Per Minute (9" Screw Conveyor)
- Part Number: BST350P-RD-EB

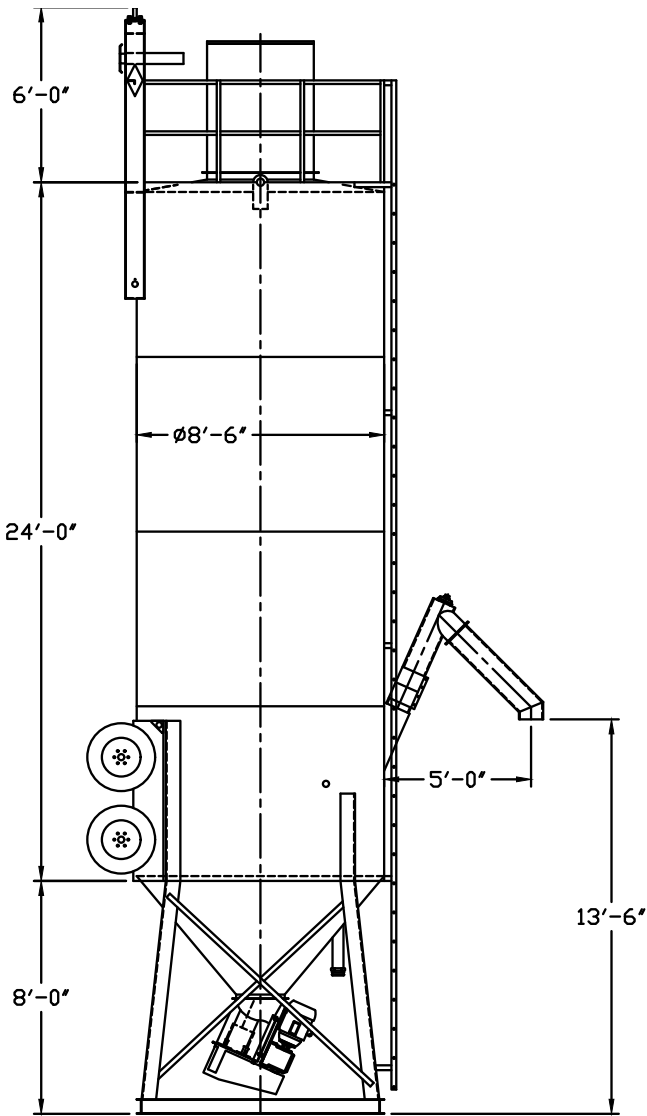

350 Barrel Round Portable Silo

Positive Feed Drive System

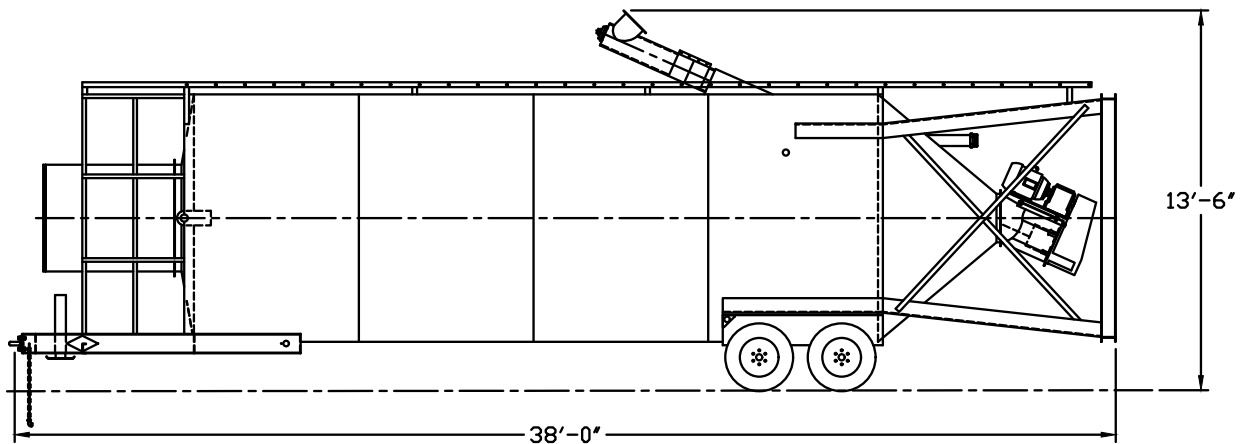
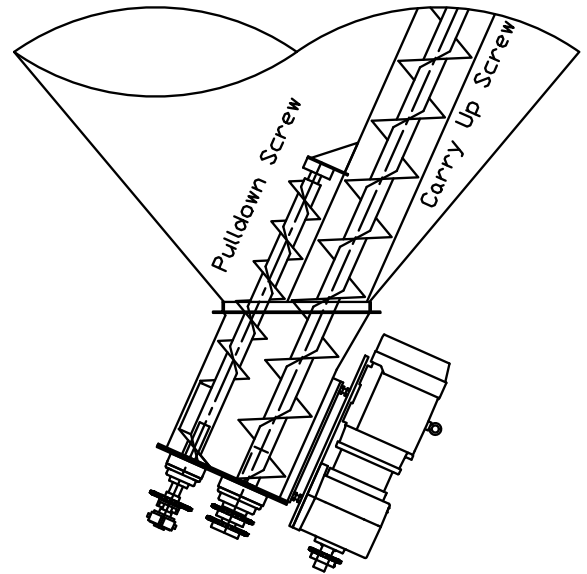

450 Barrel Round Portable Silo



450 Barrel Round Portable Silo

- 10'-8" Diameter x 35'-7" Overall Height
- Positive Feed Drive Auger System
- 9" Diameter Screw x 17'-0"
- 10 HP Motor and Gear Box Drive
- Heavy Duty Dual Axle Trailer and Tires
- Electric Brakes and Lights Package
- 150 Sq. Ft. Bag Area Dust Collector with Air Vibrator
- Pressure Relief Valve
- Two Speed Trailer Jack Set
- 14'-0" Auger Discharge Height
- Outside Ladder with OSHA Compliant Fall Arrest Cable System
- 4" Fill Pipe with Aluminum Adapter
- 20" Non-Pressurized Inspection Manhole
- (8) Externally Mounted Air Pads with Manifold, Regulator, and Check Valve
- Sandblast, Prime, and Paint
- Standard Colors:
RAL 7038 Gray, RAL 9010 White,
RAL 1001 Tan, RAL 1032 Yellow

Options

- 225 Sq. Ft. Dust Collector
- 330 Sq. Ft. Pulse Jet Dust Collector
- Bin Level Indicators
- Single Phase Motor
- Hydraulic Drive Motor
- Motor Starter Controls
- Manual Air Valve Controls
- Upgrade to 12" Screw Conveyor
- 5" Fill Pipe

Specifications

- Empty Weight 12,800#
- Hitch Weight 4,900#
- 1,800 Cu. Ft. Capacity
- 85 Ton Capacity (Cement)
- Output Capacity Approximately 15 Cu. Ft. Per Minute (9" Screw Conveyor)
- Part Number: BST450P-RD-EB

BELGRADE
STEEL TANK



450 Barrel Round Portable Silo

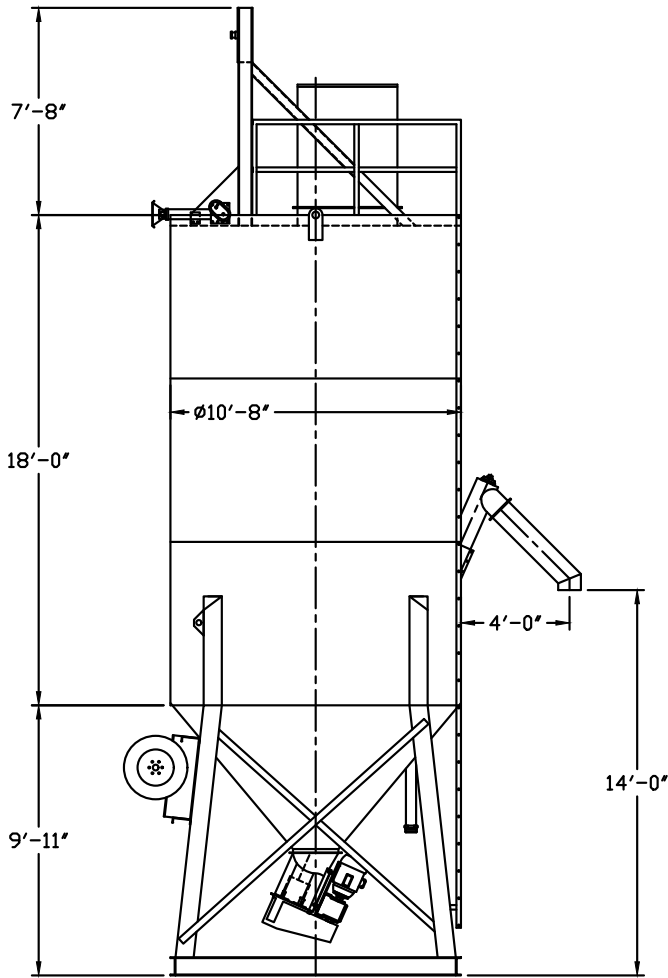

Positive Feed Drive System

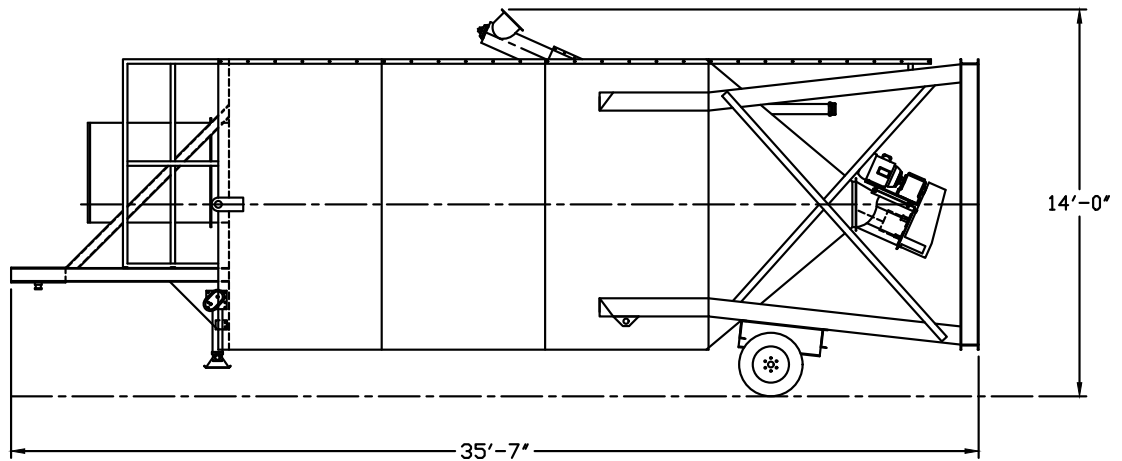
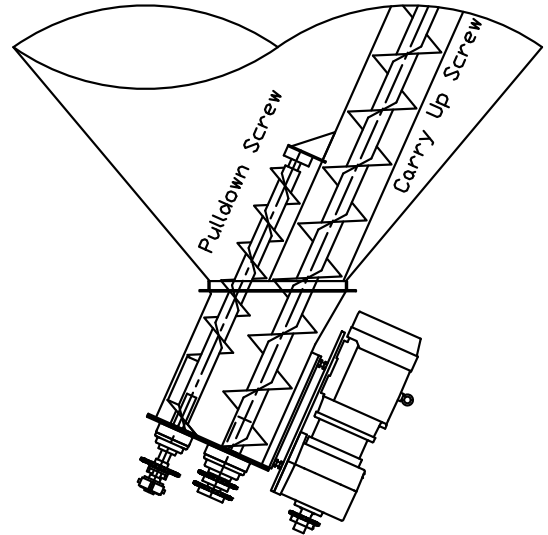

550 Barrel Round Portable Silo



550 Barrel Round Portable Silo

- 10'-8" Diameter x 41'-7" Overall Height
- Positive Feed Drive Auger System
- 9" Diameter Screw x 17'-0"
- 10 HP Motor and Gear Box Drive
- Heavy Duty Dual Axle Trailer and Tires
- Electric Brakes and Lights Package
- 150 Sq. Ft. Bag Area Dust Collector with Air Vibrator
- Pressure Relief Valve
- Two Speed Trailer Jack Set
- 14'-0" Auger Discharge Height
- Outside Ladder with OSHA Compliant Fall Arrest Cable System
- 4" Fill Pipe with Aluminum Adapter
- 20" Non-Pressurized Inspection Manhole
- (8) Externally Mounted Air Pads with Manifold, Regulator, and Check Valve
- Sandblast, Prime, and Paint
- Standard Colors:
RAL 7038 Gray, RAL 9010 White,
RAL 1001 Tan, RAL 1032 Yellow

Options

- 225 Sq. Ft. Dust Collector
- 330 Sq. Ft. Pulse Jet Dust Collector
- Bin Level Indicators
- Single Phase Motor
- Hydraulic Drive Motor
- Motor Starter Controls
- Manual Air Valve Controls
- Air Brakes and Lights Package
- Upgrade to 12" Screw Conveyor
- 5" Fill Pipe

Specifications

- Empty Weight 14,300#
- Hitch Weight 5,400#
- 2,200 Cu. Ft. Capacity
- 100 Ton Capacity (Cement)
- Output Capacity Approximately 15 Cu. Ft. Per Minute (9" Screw Conveyor)
- Part Number: BST550P-RD-EB

**BELGRADE
STEEL TANK**



550 Barrel Round Portable Silo

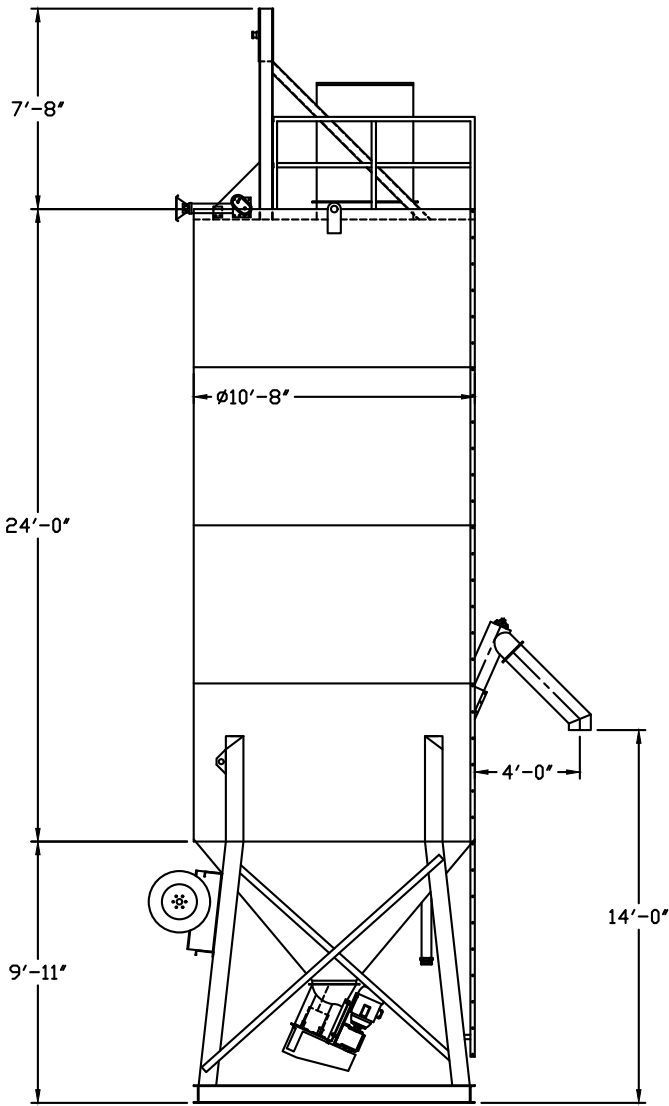

Positive Feed Drive System

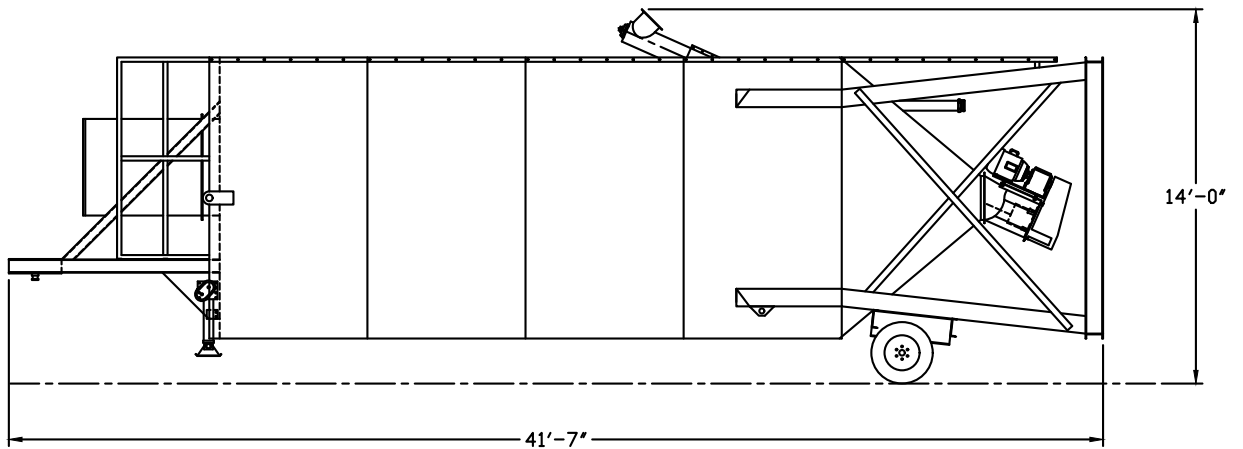
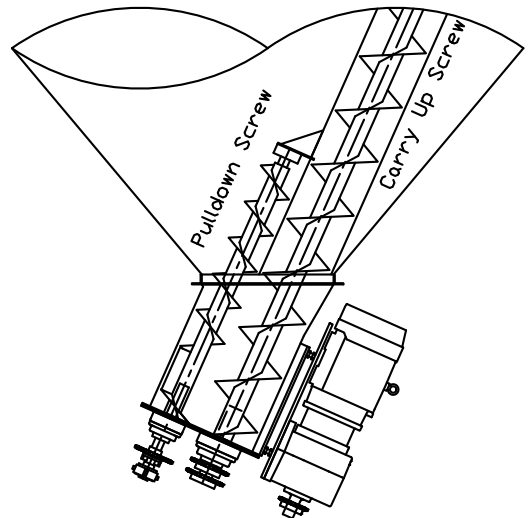

700 Barrel Round Portable Silo



700 Barrel Round Portable Silo

- 12'-0" Diameter x 41'-7" Overall Height
- Positive Feed Drive Auger System
- 9" Diameter Screw x 17'-0"
- 10 HP Motor and Gear Box Drive
- Heavy Duty Dual Axle Trailer and Tires
- Air Brakes and Lights Package
- 150 Sq. Ft. Bag Area Dust Collector with Air Vibrator
- Pressure Relief Valve
- Two Speed Trailer Jack Set
- 14'-5" Auger Discharge Height
- Outside Ladder with OSHA Compliant Fall Arrest Cable System
- 4" Fill Pipe with Aluminum Adapter
- 20" Non-Pressurized Inspection Manhole
- (8) Externally Mounted Air Pads with Manifold, Regulator, and Check Valve
- Sandblast, Prime, and Paint
- Standard Colors:
RAL 7038 Gray, RAL 9010 White,
RAL 1001 Tan, RAL 1032 Yellow

Options

- 225 Sq. Ft. Dust Collector
- 330 Sq. Ft. Pulse Jet Dust Collector
- Bin Level Indicators
- Single Phase Motor
- Hydraulic Drive Motor
- Motor Starter Controls
- Manual Air Valve Controls
- Upgrade to 12" Screw Conveyor
- 5" Fill Pipe

Specifications

- Empty Weight 18,800#
- Hitch Weight 7,500#
- 2,800 Cu. Ft. Capacity
- 130 Ton Capacity (Cement)
- Output Capacity Approximately 15 Cu. Ft. Per Minute (9" Screw Conveyor)
- Part Number: BST700P-RD-AB

**BELGRADE
STEEL TANK**



700 Barrel Round Portable Silo

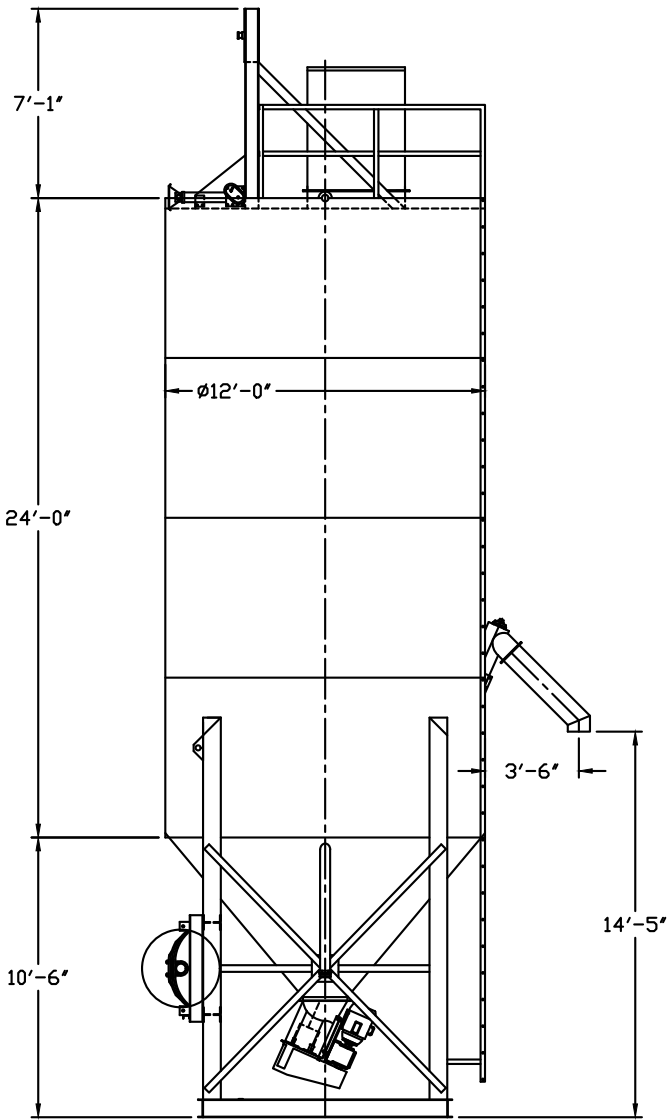

Positive Feed Drive System

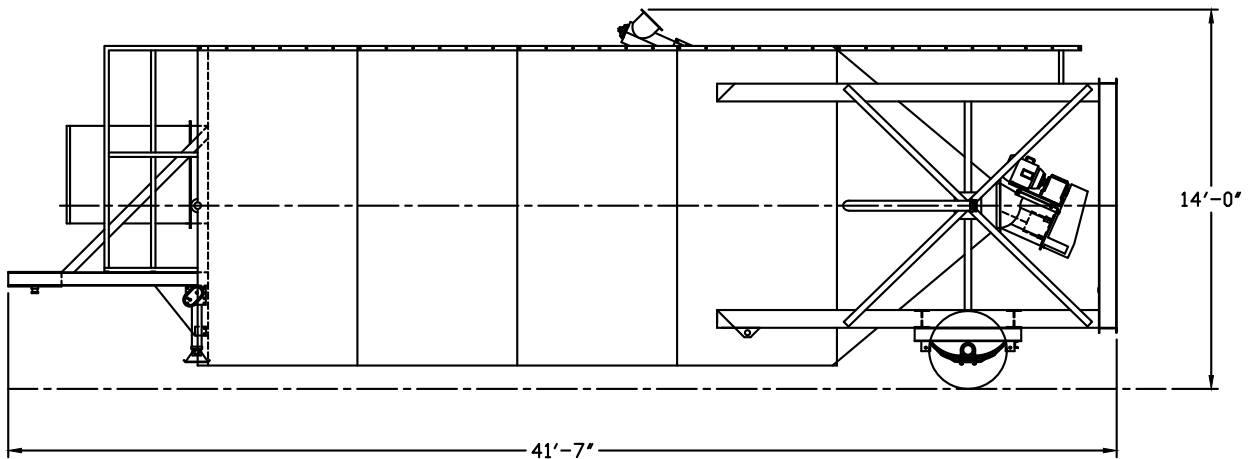
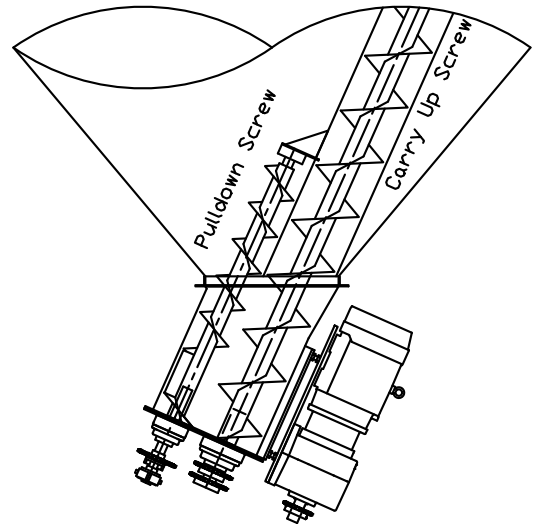

900 Barrel Round Portable Silo



900 Barrel Round Portable Silo

- 12'-0" Diameter x 47'-7" Overall Height
- Positive Feed Drive Auger System
- 9" Diameter Screw x 17'-0"
- 10 HP Motor and Gear Box Drive
- Heavy Duty Dual Axle Trailer and Tires
- Air Brakes and Lights Package
- 150 Sq. Ft. Bag Area Dust Collector with Air Vibrator
- Pressure Relief Valve
- Two Speed Trailer Jack Set
- 13'-6" Auger Discharge Height
- Outside Ladder with OSHA Compliant Fall Arrest Cable System
- 4" Fill Pipe with Aluminum Adapter
- 20" Non-Pressurized Inspection Manhole
- (8) Externally Mounted Air Pads with Manifold, Regulator, and Check Valve
- Sandblast, Prime, and Paint
- Standard Colors:
RAL 7038 Gray, RAL 9010 White,
RAL 1001 Tan, RAL 1032 Yellow

Options

- 225 Sq. Ft. Dust Collector
- 330 Sq. Ft. Pulse Jet Dust Collector
- Bin Level Indicators
- Single Phase Motor
- Hydraulic Drive Motor
- Motor Starter Controls
- Manual Air Valve Controls
- Upgrade to 12" Screw Conveyor
- 5" Fill Pipe

Specifications

- Empty Weight 20,600#
- Hitch Weight 8,100#
- 3,600 Cu. Ft. Capacity
- 170 Ton Capacity (Cement)
- Output Capacity Approximately 15 Cu. Ft. Per Minute (9" Screw Conveyor)
- Part Number: BST900P-RD-AB

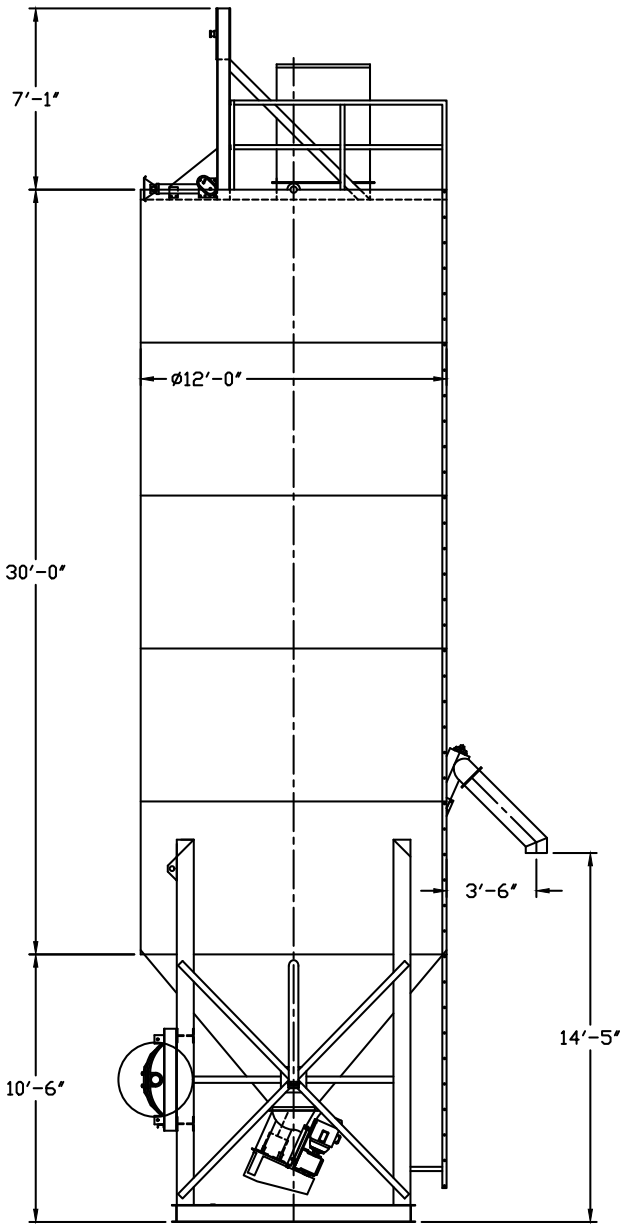

900 Barrel Round Portable Silo

Positive Feed Drive System

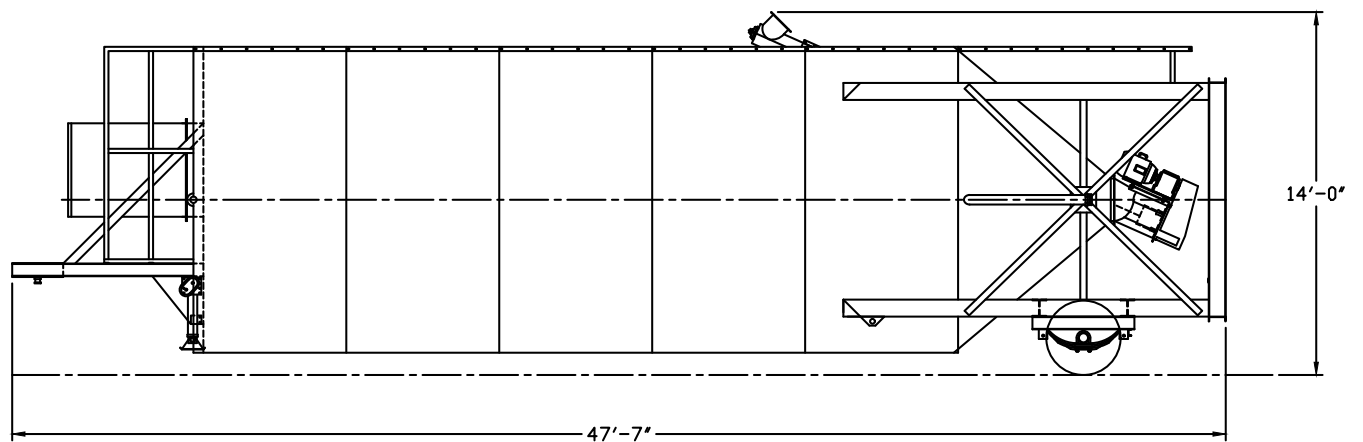
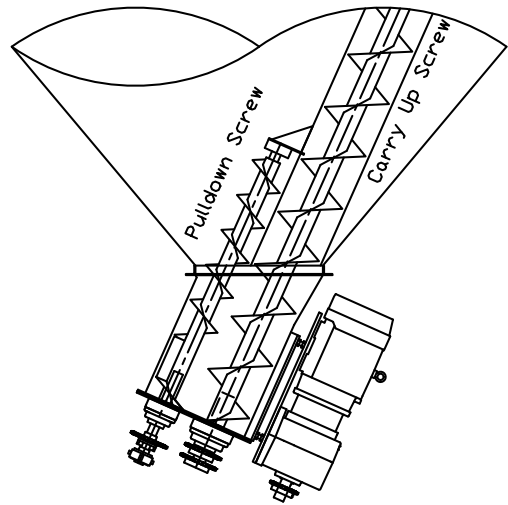

1050 Barrel Round Portable Silo



1050 Barrel Round Portable Silo

- 12'-0" Diameter x 53'-7" Overall Height
- Positive Feed Drive Auger System
- 12" Diameter Screw x 16'-3"
- 20 HP Motor and Gear Box Drive
- Heavy Duty Dual Axle Trailer and Tires
- Air Brakes and Lights Package
- 150 Sq. Ft. Bag Area Dust Collector with Air Vibrator
- Pressure Relief Valve
- Two Speed Trailer Jack Set
- 13'-6" Auger Discharge Height
- Outside Ladder with OSHA Compliant Fall Arrest Cable System
- 4" Fill Pipe with Aluminum Adapter
- 20" Non-Pressurized Inspection Manhole
- (8) Externally Mounted Air Pads with Manifold, Regulator, and Check Valve
- Sandblast, Prime, and Paint
- Standard Colors:
RAL 7038 Gray, RAL 9010 White,
RAL 1001 Tan, RAL 1032 Yellow

Options

- 225 Sq. Ft. Dust Collector
- 330 Sq. Ft. Pulse Jet Dust Collector
- Bin Level Indicators
- Motor Starter Controls
- Manual Air Valve Controls
- 5" Fill Pipe

Specifications

- Empty Weight 22,400#
- Hitch Weight 8,900#
- 4,200 Cu. Ft. Capacity
- 200 Ton Capacity (Cement)
- Output Capacity Approximately 30 Cu. Ft. Per Minute (12" Screw Conveyor)
- Part Number: BST1050P-RD-AB

BELGRADE
STEEL TANK



1050 Barrel Round Portable Silo

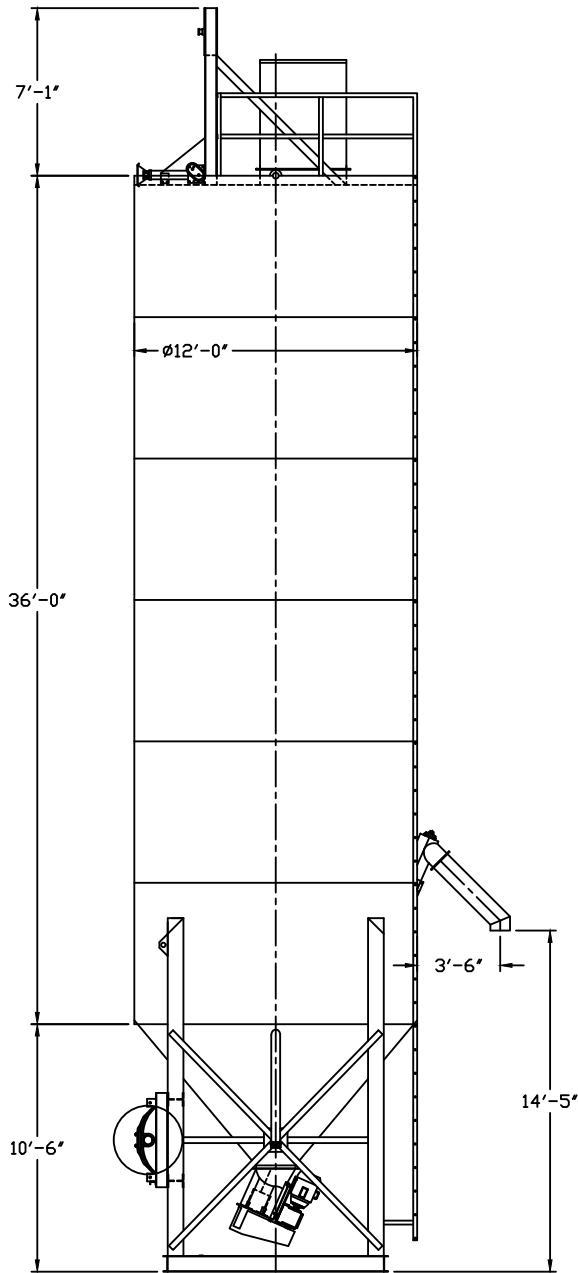

Positive Feed Drive System

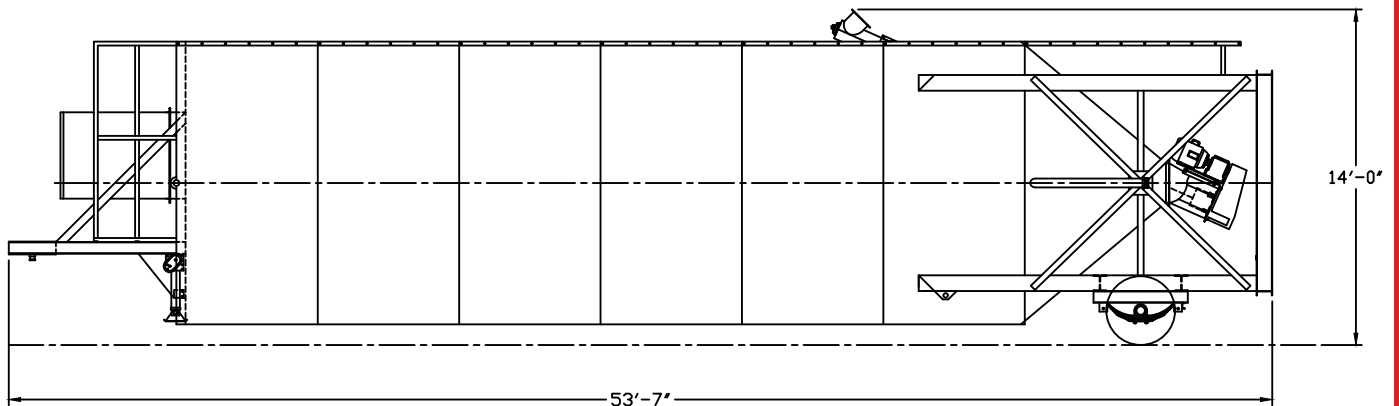
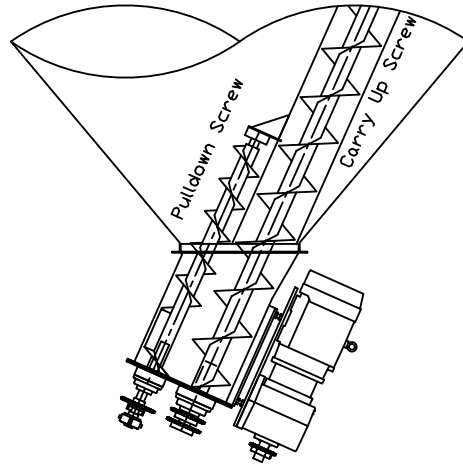

1200 Barrel Round Portable Silo



1200 Barrel Round Portable Silo

- 12'-0" Diameter x 59'-7" Overall Height
- Positive Feed Drive Auger System
- 12" Diameter Screw x 16'-3"
- 20 HP Motor and Gear Box Drive
- Heavy Duty Dual Axle Trailer and Tires
- Air Brakes and Lights Package
- 150 Sq. Ft. Bag Area Dust Collector with Air Vibrator
- Pressure Relief Valve
- Two Speed Trailer Jack Set
- 13'-6" Auger Discharge Height
- Outside Ladder with OSHA Compliant Fall Arrest Cable System
- 4" Fill Pipe with Aluminum Adapter
- 20" Non-Pressurized Inspection Manhole
- (8) Externally Mounted Air Pads with Manifold, Regulator, and Check Valve
- Sandblast, Prime, and Paint
- Standard Colors:
RAL 7038 Gray, RAL 9010 White,
RAL 1001 Tan, RAL 1032 Yellow

Options

- 225 Sq. Ft. Dust Collector
- 330 Sq. Ft. Pulse Jet Dust Collector
- Bin Level Indicators
- Motor Starter Controls
- Manual Air Valve Controls
- 5" Fill Pipe

Specifications

- Empty Weight 25,300#
- Hitch Weight 10,000#
- 4,800 Cu. Ft. Capacity
- 225 Ton Capacity (Cement)
- Output Capacity Approximately 30 Cu. Ft. Per Minute (12" Screw Conveyor)
- Part Number: BST1200P-RD-AB

BELGRADE
STEEL TANK



1200 Barrel Round Portable Silo

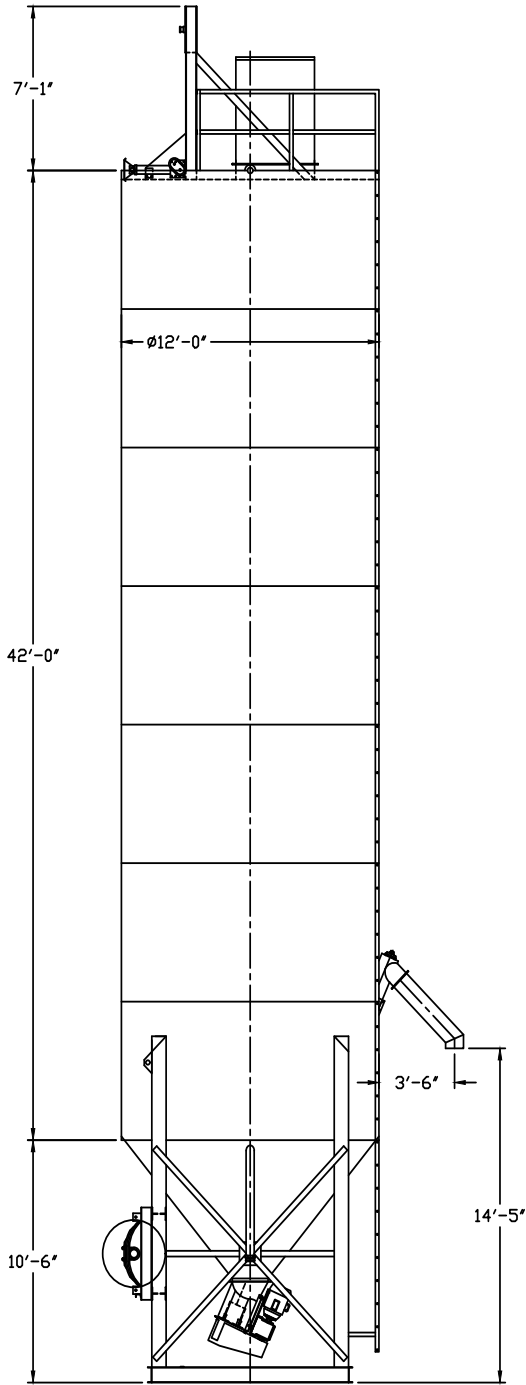

Positive Feed Drive System

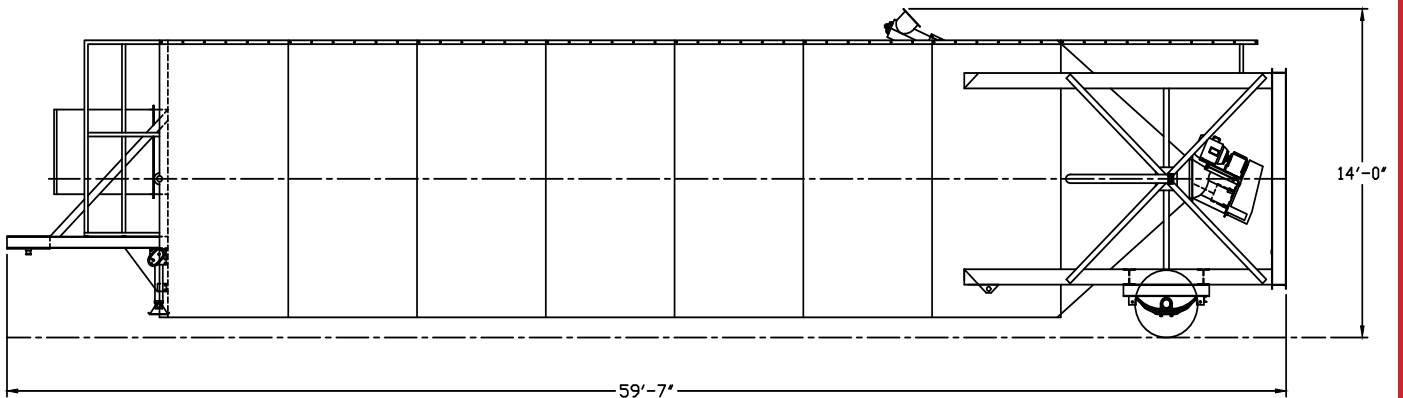
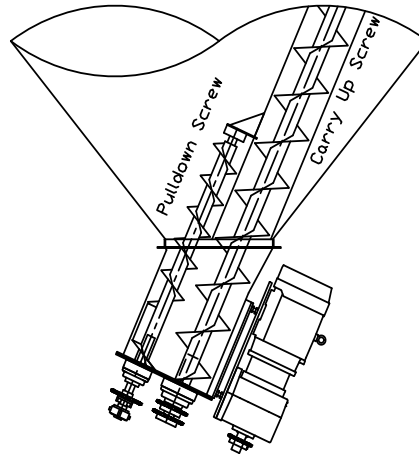

500 Barrel Round Portable Split Silo

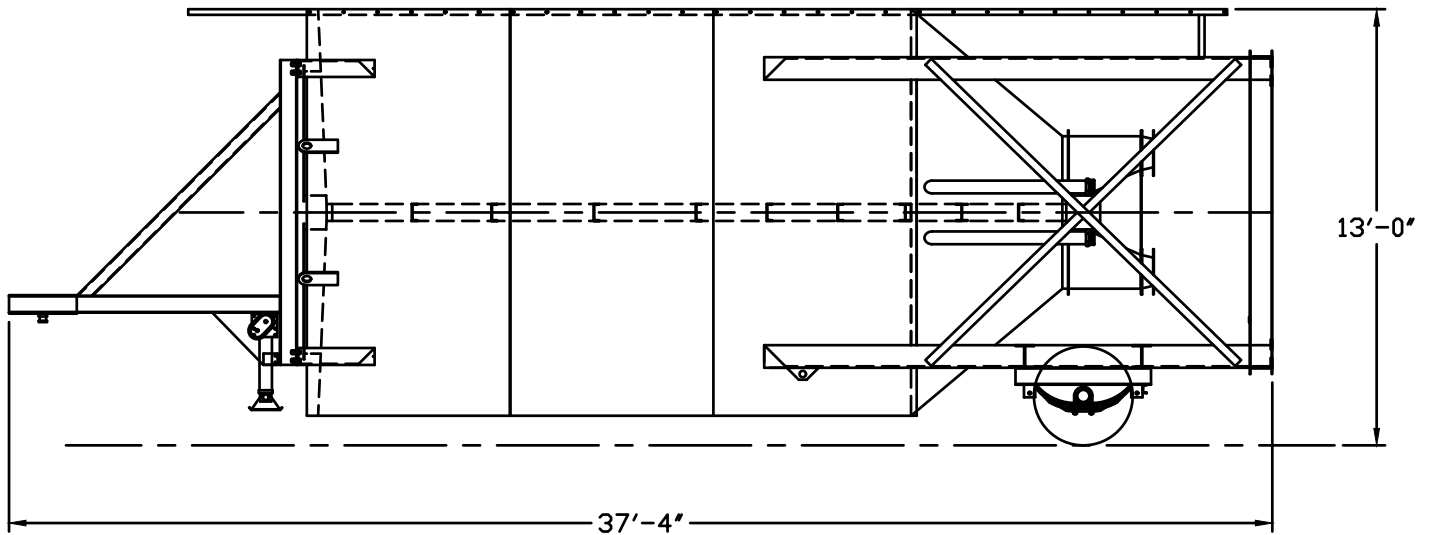

500 Barrel Portable Split Silo

- 12'-0" Diameter x 37'-4" Overall Length
- Heavy Duty Dual Axle Trailer and Tires
- Air Brakes and Lights Package
- (2) 150 Sq. Ft. Bag Area Dust Collectors with Air Vibrators
- (2) Pressure Relief Valves
- Two Speed Trailer Jack Set
- 3'-6" Clearance under Discharge
- Outside Ladder with OSHA Compliant Fall Arrest Cable System
- (2) 4" Fill Pipes with Aluminum Adapters
- (2) 20" Non-Pressurized Inspection Manholes
- (12) Externally Mounted Air Pads with Manifold, Regulator, and Check Valve
- Sandblast, Prime, and Paint
- Standard Colors:
RAL 7038 Gray, RAL 9010 White,
RAL 1001 Tan, RAL 1032 Yellow

Options

- 225 Sq. Ft. Dust Collector
- 330 Sq. Ft. Pulse Jet Dust Collector
- Bin Level Indicators
- Manual Air Valve Controls
- 5" Fill Pipes

Specifications

- Empty Weight: 19,100#
- Hitch Weight: 7,400#
- 2,000 Cu. Ft. Capacity
- 94 Ton Capacity (Cement)
- Part Number: BST500PS-AB

500 Barrel Portable Split Silo

BELGRADE
STEEL TANK

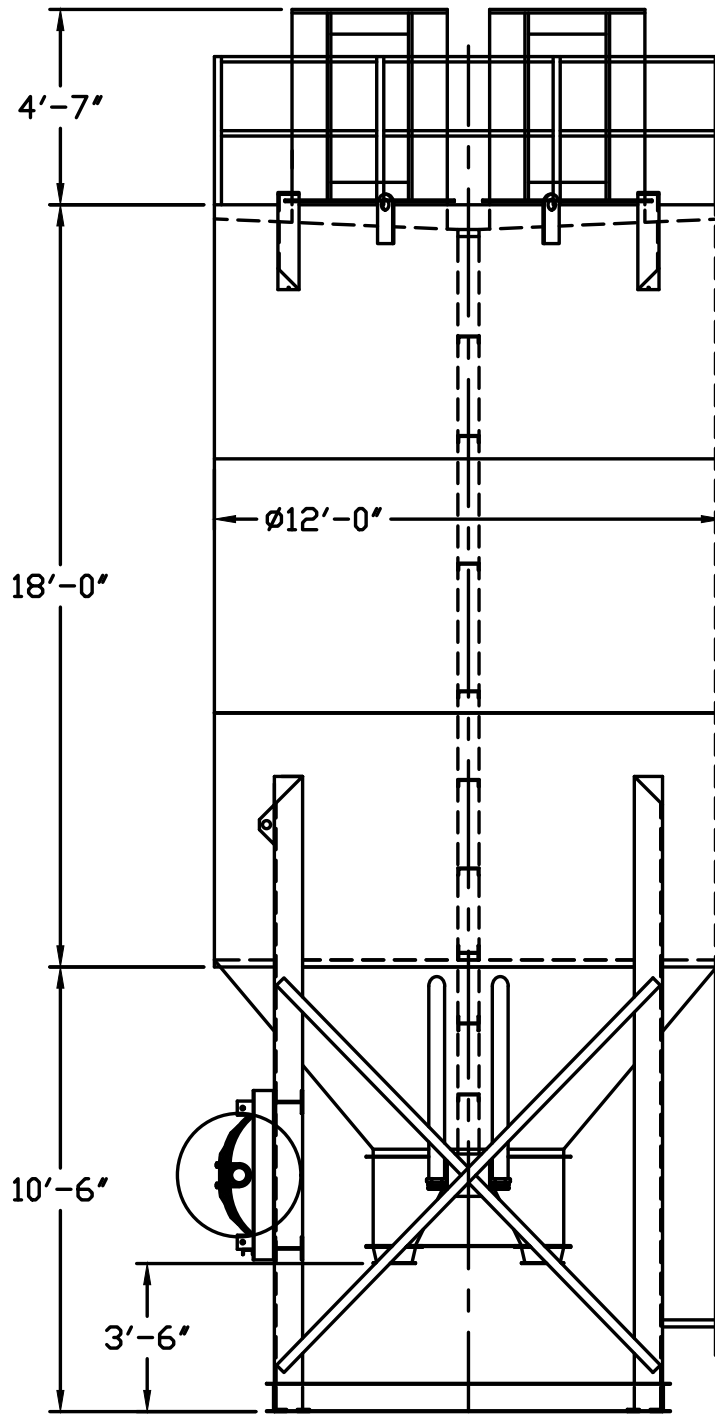

700 Barrel Round Portable Split Silo

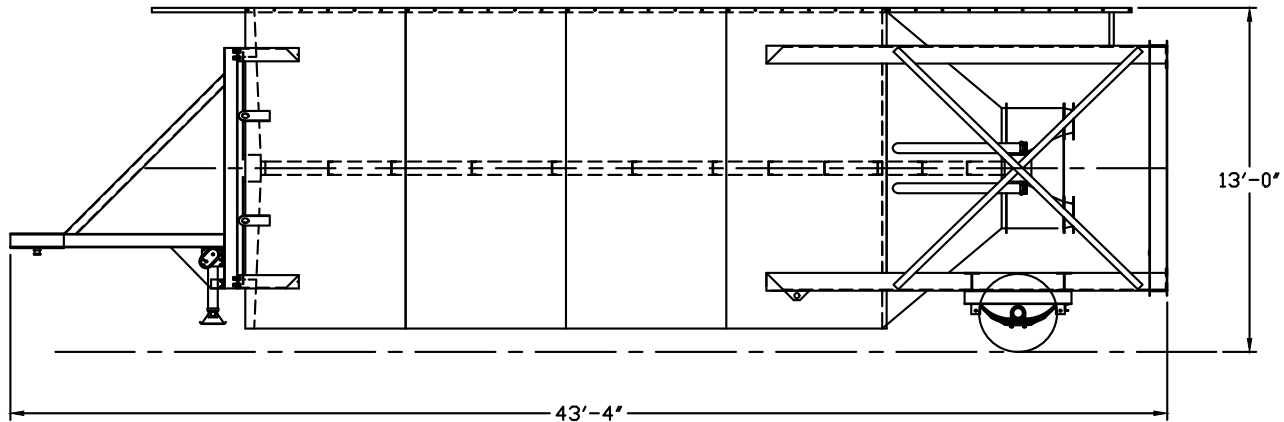

700 Barrel Portable Split Silo

- 12'-0" Diameter x 43'-4" Overall Length
- Heavy Duty Dual Axle Trailer and Tires
- Air Brakes and Lights Package
- (2) 150 Sq. Ft. Bag Area Dust Collectors with Air Vibrators
- (2) Pressure Relief Valves
- Two Speed Trailer Jack Set
- 3'-6" Clearance under Discharge
- Outside Ladder with OSHA Compliant Fall Arrest Cable System
- (2) 4" Fill Pipes with Aluminum Adapters
- (2) 20" Non-Pressurized Inspection Manholes
- (12) Externally Mounted Air Pads with Manifold, Regulator, and Check Valve
- Sandblast, Prime, and Paint
- Standard Colors:
RAL 7038 Gray, RAL 9010 White,
RAL 1001 Tan, RAL 1032 Yellow

Options

- 225 Sq. Ft. Dust Collector
- 330 Sq. Ft. Pulse Jet Dust Collector
- Bin Level Indicators
- Manual Air Valve Controls
- 5" Fill Pipes

Specifications

- Empty Weight: 24,800#
- Hitch Weight: 9,800#
- 2,600 Cu. Ft. Capacity
- 122 Ton Capacity (Cement)
- Part Number: BST700PS-AB

700 Barrel Portable Split Silo

BELGRADE
STEEL TANK

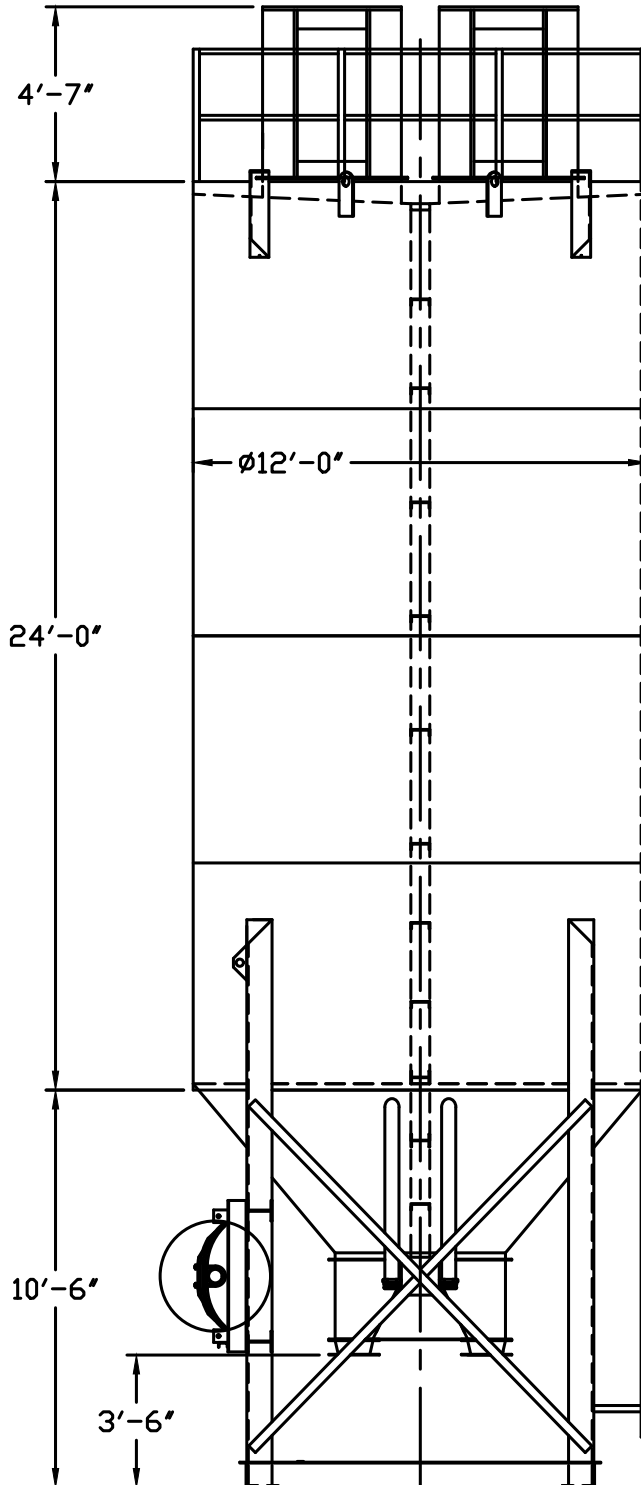

850 Barrel Round Portable Split Silo

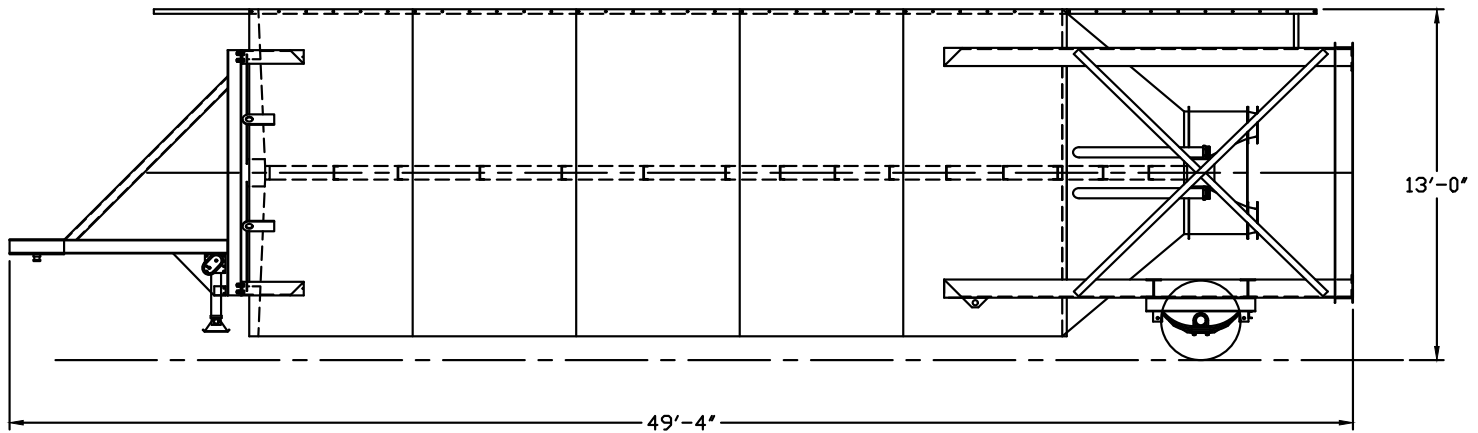

850 Barrel Portable Split Silo

- 12'-0" Diameter x 49'-4" Overall Length
- Heavy Duty Dual Axle Trailer and Tires
- Air Brakes and Lights Package
- (2) 150 Sq. Ft. Bag Area Dust Collectors with Air Vibrators
- (2) Pressure Relief Valves
- Two Speed Trailer Jack Set
- 3'-6" Clearance under Discharge
- Outside Ladder with OSHA Compliant Fall Arrest Cable System
- (2) 4" Fill Pipes with Aluminum Adapters
- (2) 20" Non-Pressurized Inspection Manholes
- (12) Externally Mounted Air Pads with Manifold, Regulator, and Check Valve
- Sandblast, Prime, and Paint
- Standard Colors:
RAL 7038 Gray, RAL 9010 White,
RAL 1001 Tan, RAL 1032 Yellow

Options

- 225 Sq. Ft. Dust Collector
- 330 Sq. Ft. Pulse Jet Dust Collector
- Bin Level Indicators
- Manual Air Valve Controls
- 5" Fill Pipes

Specifications

- Empty Weight: 27,800#
- Hitch Weight: 11,000#
- 3,400 Cu. Ft. Capacity
- 158 Ton Capacity (Cement)
- Part Number: BST850PS-AB

850 Barrel Portable Split Silo

BELGRADE
STEEL TANK

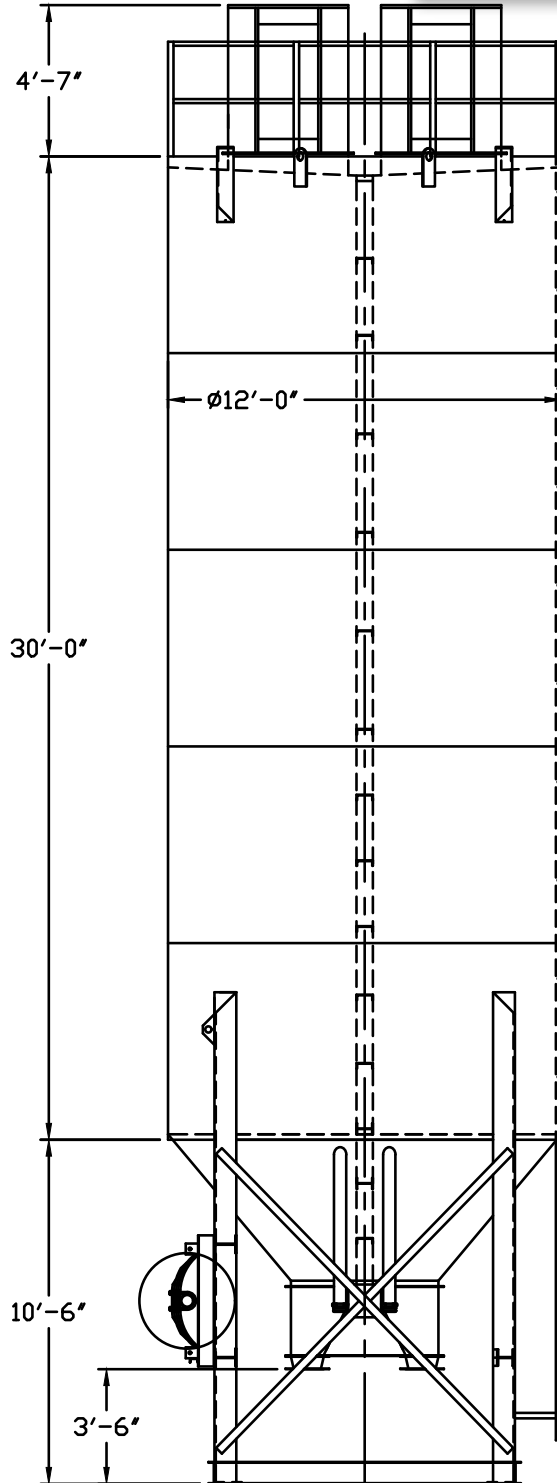

200 Low Profile Portable Silo



200 Barrel Low Profile Portable

- 8'-6" Wide x 25'-9" Overall Length
- Positive Feed Drive Auger System
- 7" Diameter Screw x 17'-0"
- 5 HP Motor and Gear Box Drive
- Heavy Duty Dual Axle Trailer and Tires
- Electric Brakes and Lights Package
- 150 Sq. Ft. Bag Area Dust Collector with Air Vibrator
- Pressure Relief Valve
- (4) Two Speed Trailer Jacks
- 12'-0" Auger Discharge Height
- 4" Fill Pipe with Aluminum Adapter
- 20" Non-Pressurized Inspection Manhole
- (8) Externally Mounted Air Pads with Manifold, Regulator, and Check Valve
- Sandblast, Prime, and Paint
- Standard Colors:
RAL 7038 Gray, RAL 9010 White,
RAL 1001 Tan, RAL 1032 Yellow

Options

- 225 Sq. Ft. Dust Collector
- 330 Sq. Ft. Pulse Jet Dust Collector
- Bin Level Indicators
- Single Phase Motor
- Hydraulic Drive Motor
- 16 HP Gas Motor
- Motor Starter Controls
- Manual Air Valve Controls
- Upgrade to 9" Screw Conveyor

Specifications

- Empty Weight 8,000#
- Hitch Weight 2,100#
- 800 Cu. Ft. Capacity
- 37 Ton Capacity (Cement)
- Output Capacity Approximately 7 Cu. Ft. Per Minute (7" Screw Conveyor)

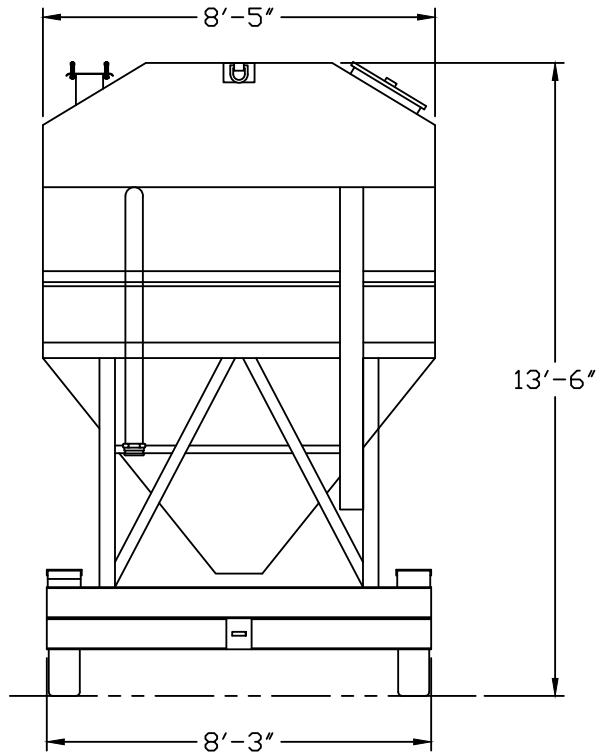

200 Low Profile Portable Silo

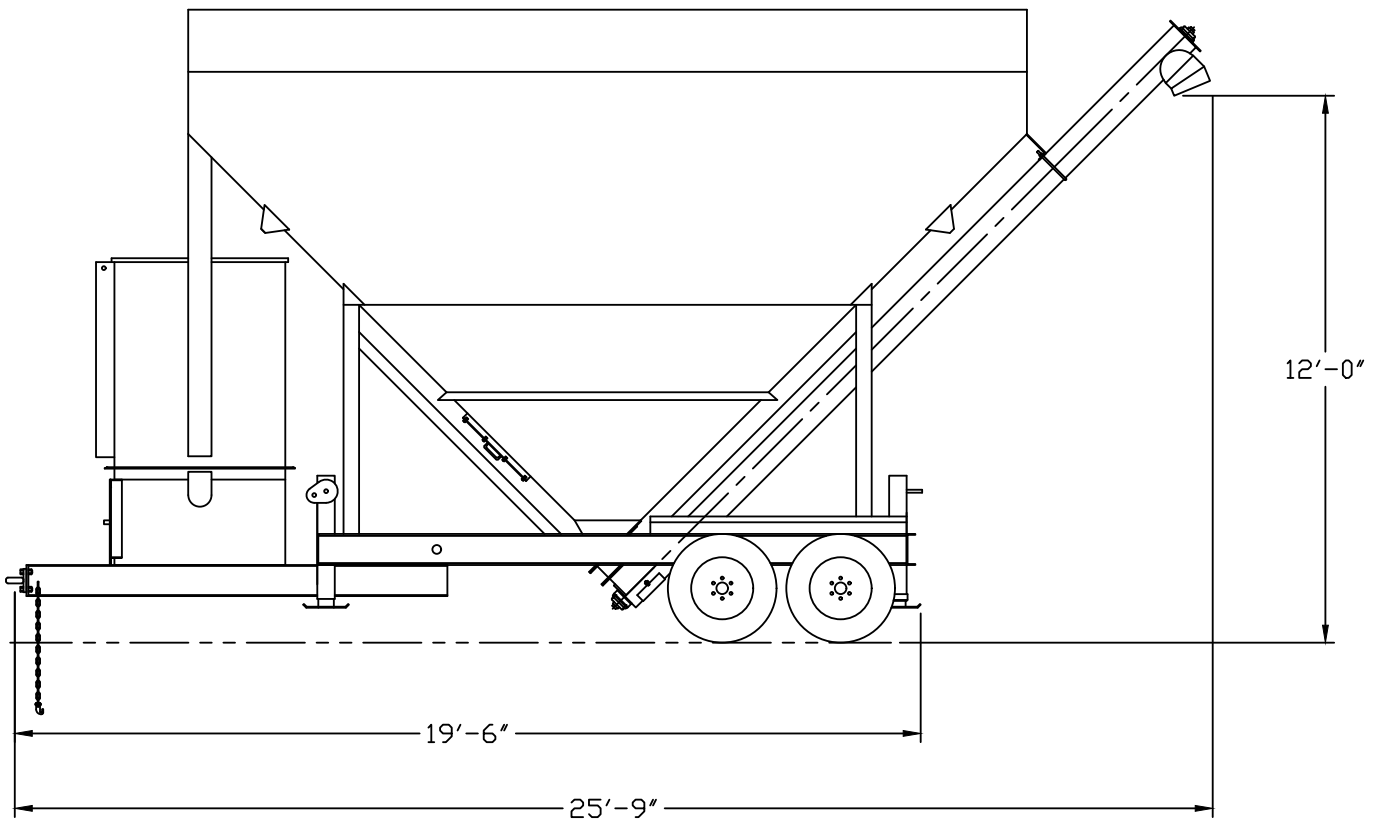

300 Low Profile Portable Silo



300 Barrel Low Profile Portable

- 8'-6" Wide x 34'-3" Overall Length
- Positive Feed Drive Auger System
- 7" Diameter Carry Across and 9" Diameter Discharge Screw x 17'-0"
- 10 HP Motor and Gear Box Drive
- Heavy Duty Dual Axle Trailer and Tires
- Electric Brakes and Lights Package
- 150 Sq. Ft. Bag Area Dust Collector with Air Vibrator
- Pressure Relief Valve
- (4) Two Speed Trailer Jacks
- 12'-0" Auger Discharge Height
- 4" Fill Pipe with Aluminum Adapter
- 20" Non-Pressurized Inspection Manhole
- (24) Externally Mounted Air Pads with Manifold, Regulator, and Check Valve
- Sandblast, Prime, and Paint
- Standard Colors:
RAL 7038 Gray, RAL 9010 White,
RAL 1001 Tan, RAL 1032 Yellow

Options

- 225 Sq. Ft. Dust Collector
- 330 Sq. Ft. Pulse Jet Dust Collector
- Bin Level Indicators
- Single Phase Motor
- Hydraulic Drive Motor
- Motor Starter Controls
- Manual Air Valve Controls
- Air Brakes and Lights Package
- Upgrade to 9" Carry Across and 12" Discharge Screw Conveyor

Specifications

- Empty Weight 15,000#
- Hitch Weight 5,600#
- 1,200 Cu. Ft. Capacity
- 56 Ton Capacity (Cement)
- Output Capacity Approximately 15 Cu. Ft. Per Minute (9" Screw Conveyor)



300 Low Profile Portable Silo

