

Belgrade Basic Cement Silos





Table of Contents

185 Barrel Basic Silo.....	8
270 Barrel Basic Silo.....	9
350 Barrel Basic Silo.....	10
450 Barrel Basic Silo.....	11
550 Barrel Basic Silo.....	12
700 Barrel Basic Silo.....	13
900 Barrel Basic Silo.....	14
1050 Barrel Basic Silo.....	15
1200 Barrel Basic Silo.....	16
500 Barrel Split Silo	17
700 Barrel Split Silo	18
850 Barrel Split Silo	19
1000 Barrel Split Silo	20
1200 Barrel Split Silo	21

185 Barrel Basic Cement Silo

**BELGRADE
STEEL TANK**



185 Barrel Basic Cement Silo

- 8'-6" Diameter x 25'-4" Overall Height
- 150 Sq. Ft. Bag Area Dust Collector with Air Vibrator
- Pressure Relief Valve
- 3'-8" Clearance Under Discharge
- Outside Ladder with OSHA Compliant Fall Arrest Cable System
- 4" Fill Pipe with Aluminum Adapter
- 18" Non-Pressurized Inspection Manhole
- (8) Externally Mounted Air Pads with Manifold, Regulator, and Check Valve
- Emergency Jam Gate
- Sandblast, Prime, and Paint
- Standard Colors:
- RAL 7038 Gray, RAL 9010 White, RAL 1001 Tan, RAL 1032 Yellow

Options

- 225 Sq. Ft. Dust Collector
- 330 Sq. Ft. Pulse Jet Dust Collector
- Bin Level Indicators
- Manual Air Valve Controls
- Butterfly Valve
- 5" Fill Pipe

Specifications

- Empty Weight 6,000#
- 740 Cu. Ft. Capacity
- 34 Ton Capacity (Cement)
- Part Number: BST185-86

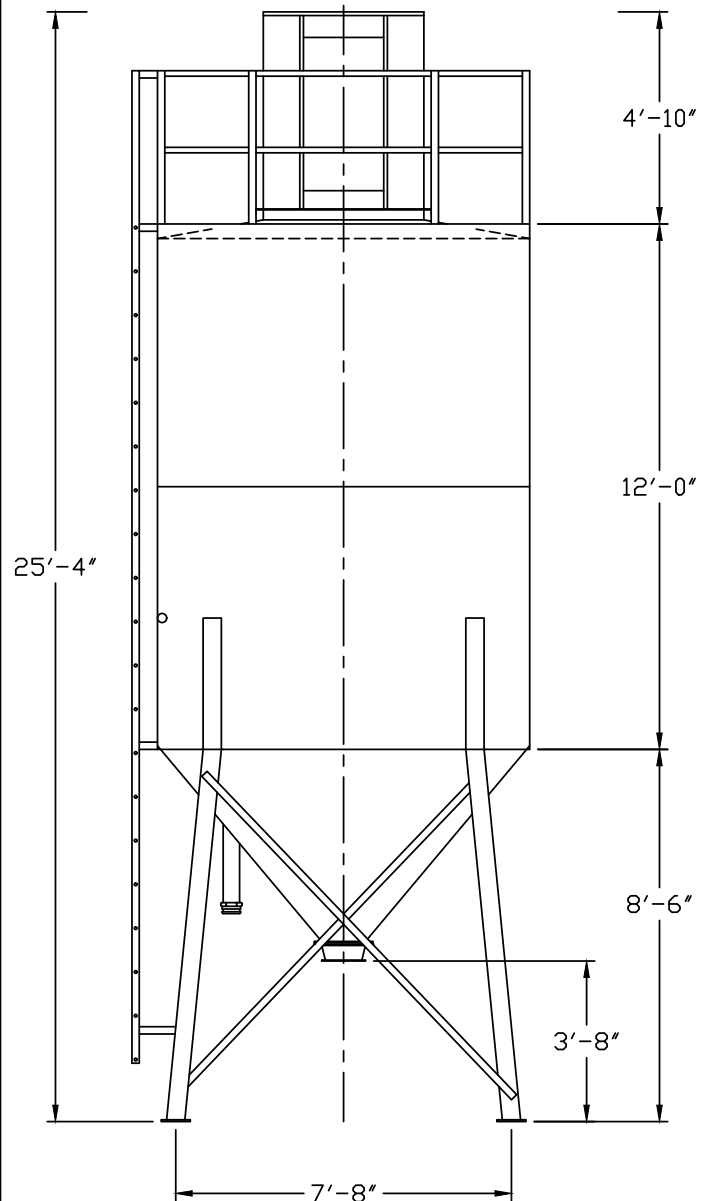
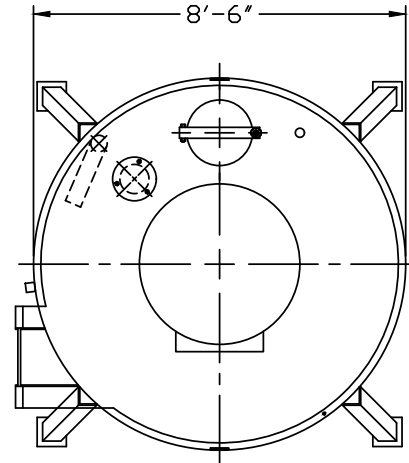

270 Barrel Basic Cement Silo

**BELGRADE
STEEL TANK**



270 Barrel Basic Cement Silo

- 8'-6" Diameter x 31'-4" Overall Height
- 150 Sq. Ft. Bag Area Dust Collector with Air Vibrator
- Pressure Relief Valve
- 3'-8" Clearance Under Discharge
- Outside Ladder with OSHA Compliant Fall Arrest Cable System
- 4" Fill Pipe with Aluminum Adapter
- 18" Non-Pressurized Inspection Manhole
- (8) Externally Mounted Air Pads with Manifold, Regulator, and Check Valve
- Emergency Jam Gate
- Sandblast, Prime, and Paint
- Standard Colors:
- RAL 7038 Gray, RAL 9010 White, RAL 1001 Tan, RAL 1032 Yellow

Options

- 225 Sq. Ft. Dust Collector
- 330 Sq. Ft. Pulse Jet Dust Collector
- Bin Level Indicators
- Manual Air Valve Controls
- Butterfly Valve
- 5" Fill Pipe

Specifications

- Empty Weight 7,000#
- 1,080 Cu. Ft. Capacity
- 50 Ton Capacity (Cement)
- Part Number: BST270-86

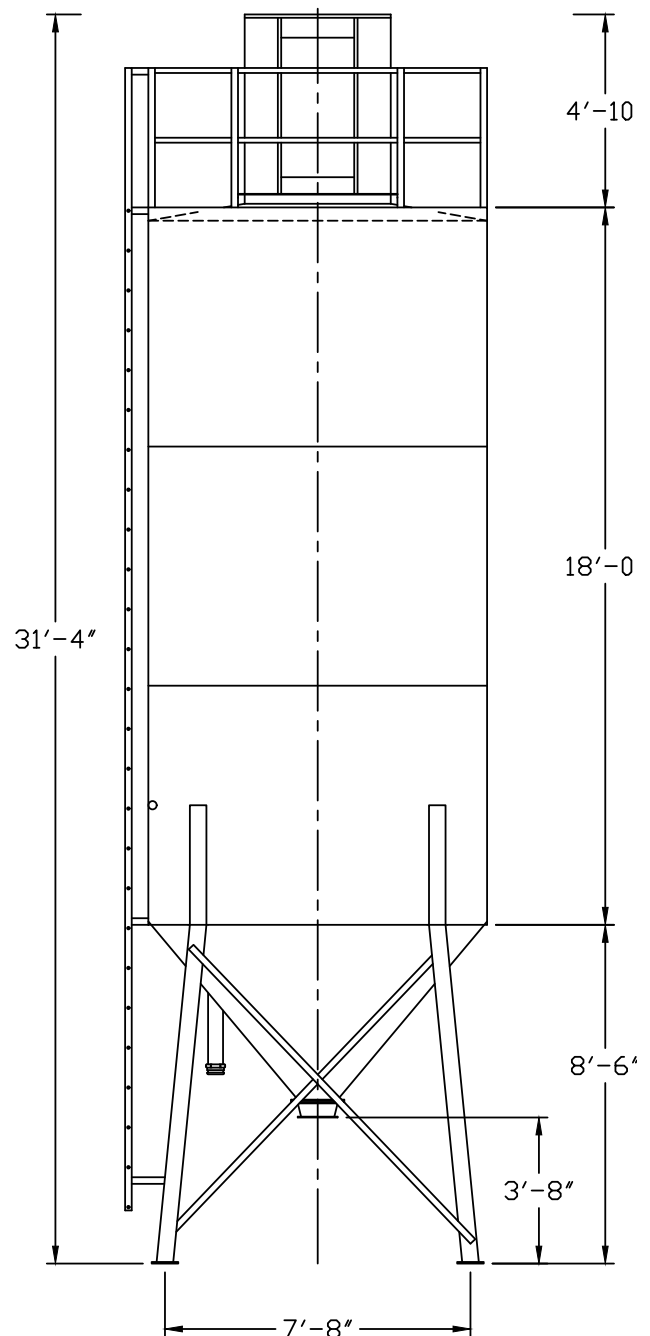
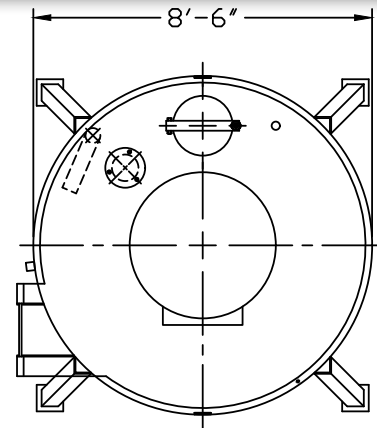

350 Barrel Basic Cement Silo

**BELGRADE
STEEL TANK**



350 Barrel Basic Cement Silo

- 8'-6" Diameter x 37'-4" Overall Height
- 150 Sq. Ft. Bag Area Dust Collector with Air Vibrator
- Pressure Relief Valve
- 3'-8" Clearance Under Discharge
- Outside Ladder with OSHA Compliant Fall Arrest Cable System
- 4" Fill Pipe with Aluminum Adapter
- 18" Non-Pressurized Inspection Manhole
- (8) Externally Mounted Air Pads with Manifold, Regulator, and Check Valve
- Emergency Jam Gate
- Sandblast, Prime, and Paint
- Standard Colors:
- RAL 7038 Gray, RAL 9010 White, RAL 1001 Tan, RAL 1032 Yellow

Options

- 225 Sq. Ft. Dust Collector
- 330 Sq. Ft. Pulse Jet Dust Collector
- Bin Level Indicators
- Manual Air Valve Controls
- Butterfly Valve
- 5" Fill Pipe

Specifications

- Empty Weight 9,000#
- 1,400 Cu. Ft. Capacity
- 65 Ton Capacity (Cement)
- Part Number: BST350-86

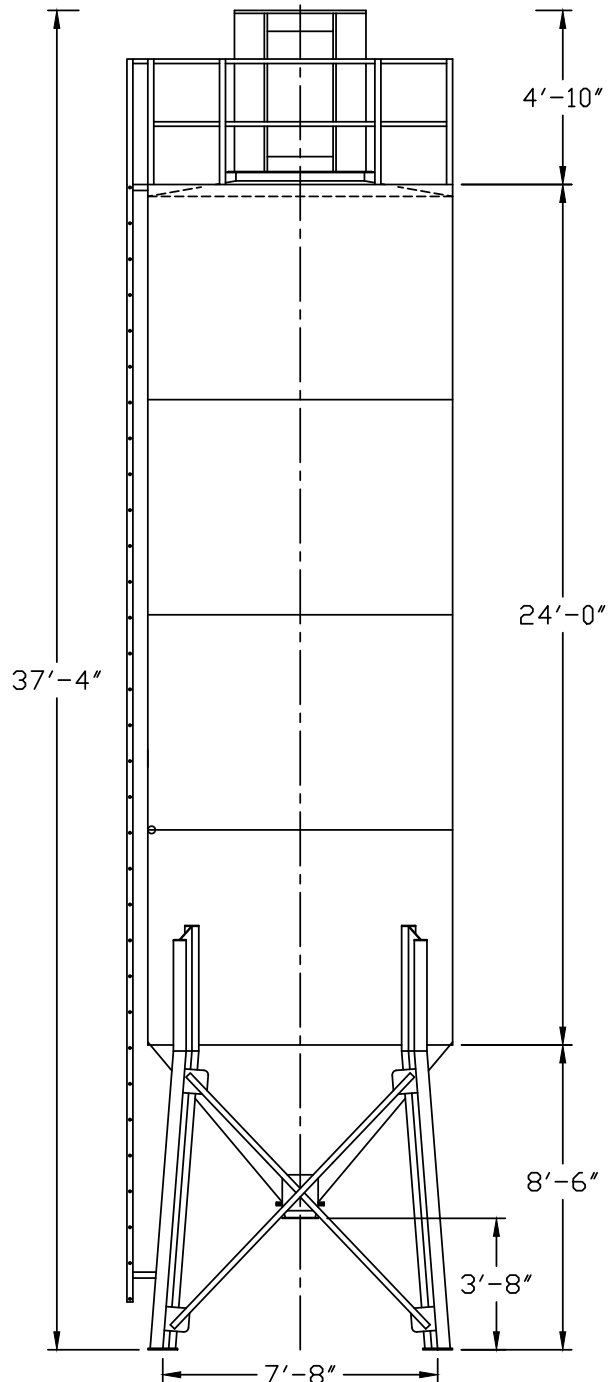
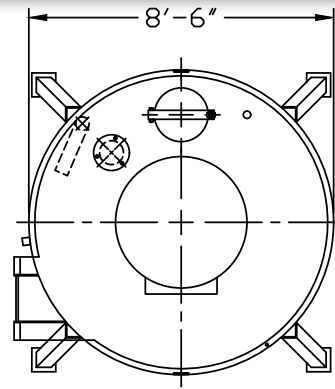

450 Barrel Basic Cement Silo

BELGRADE
STEEL TANK



450 Barrel Basic Cement Silo

- 10'-8" Diameter x 32'-11" Overall Height
- 150 Sq. Ft. Bag Area Dust Collector with Air Vibrator
- Pressure Relief Valve
- 3'-8" Clearance Under Discharge
- Outside Ladder with OSHA Compliant Fall Arrest Cable System
- 4" Fill Pipe with Aluminum Adapter
- 20" Non-Pressurized Inspection Manhole
- (8) Externally Mounted Air Pads with Manifold, Regulator, and Check Valve
- Emergency Jam Gate
- Sandblast, Prime, and Paint
- Standard Colors:
- RAL 7038 Gray, RAL 9010 White, RAL 1001 Tan, RAL 1032 Yellow

Options

- 225 Sq. Ft. Dust Collector
- 330 Sq. Ft. Pulse Jet Dust Collector
- Bin Level Indicators
- Manual Air Valve Controls
- Butterfly Valve
- 5" Fill Pipe

Specifications

- Empty Weight 10,000#
- 1,800 Cu. Ft. Capacity
- 84 Ton Capacity (Cement)
- Part Number: BST450-108

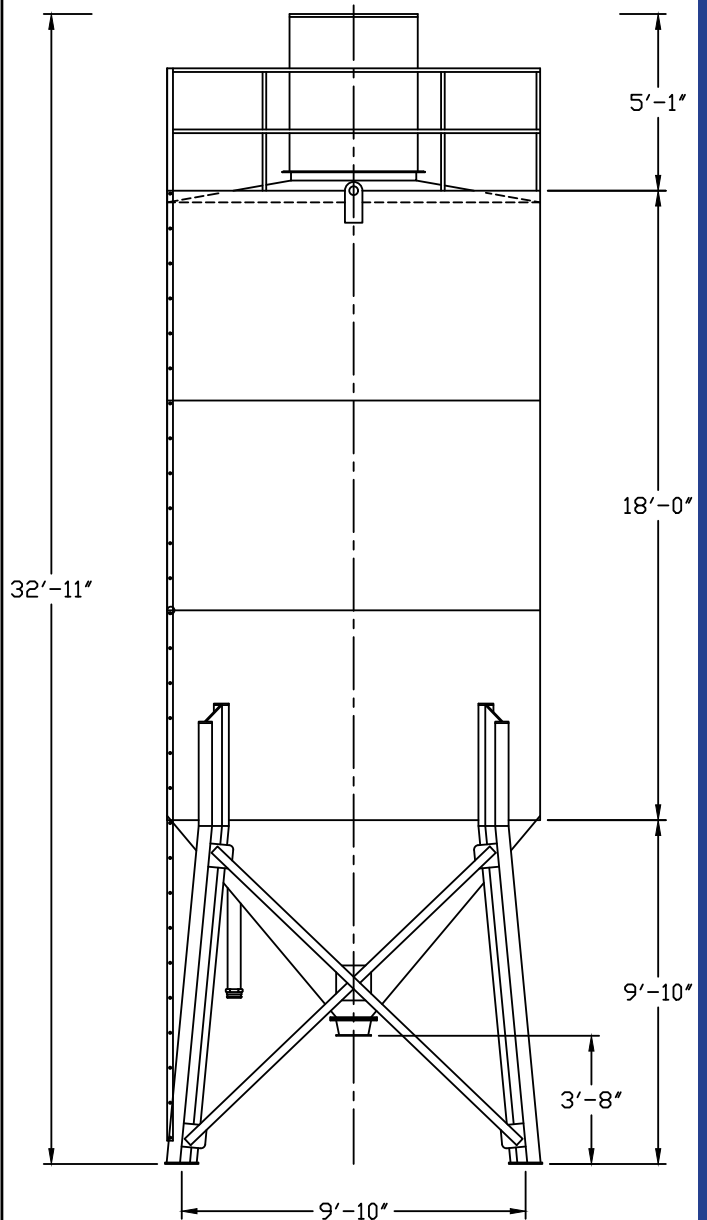
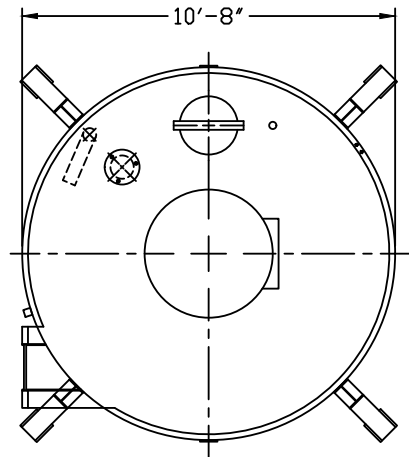

550 Barrel Basic Cement Silo

**BELGRADE
STEEL TANK**



550 Barrel Basic Cement Silo

- 10'-8" Diameter x 38'-11" Overall Height
- 150 Sq. Ft. Bag Area Dust Collector with Air Vibrator
- Pressure Relief Valve
- 3'-8" Clearance Under Discharge
- Outside Ladder with OSHA Compliant Fall Arrest Cable System
- 4" Fill Pipe with Aluminum Adapter
- 20" Non-Pressurized Inspection Manhole
- (8) Externally Mounted Air Pads with Manifold, Regulator, and Check Valve
- Emergency Jam Gate
- Sandblast, Prime, and Paint
- Standard Colors:
- RAL 7038 Gray, RAL 9010 White, RAL 1001 Tan, RAL 1032 Yellow

Options

- 225 Sq. Ft. Dust Collector
- 330 Sq. Ft. Pulse Jet Dust Collector
- Bin Level Indicators
- Manual Air Valve Controls
- Butterfly Valve
- 5" Fill Pipe

Specifications

- Empty Weight 13,000#
- 2,200 Cu. Ft. Capacity
- 100 Ton Capacity (Cement)
- Part Number: BST550-108

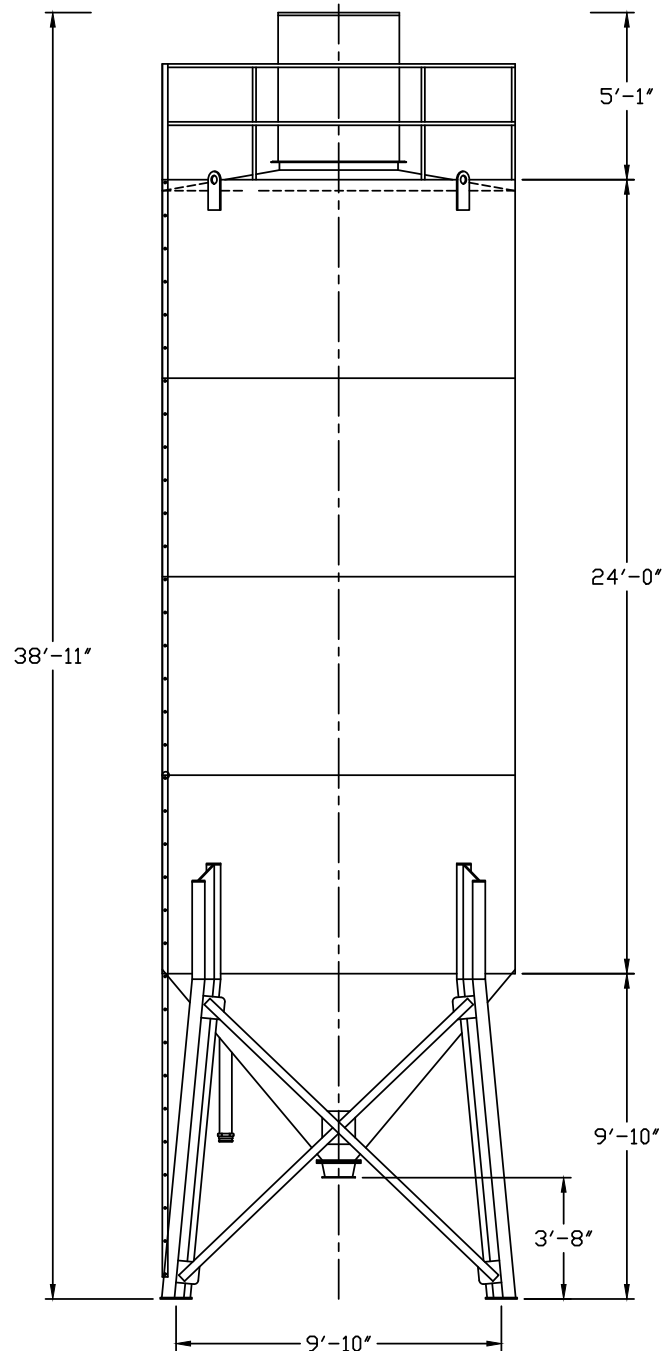
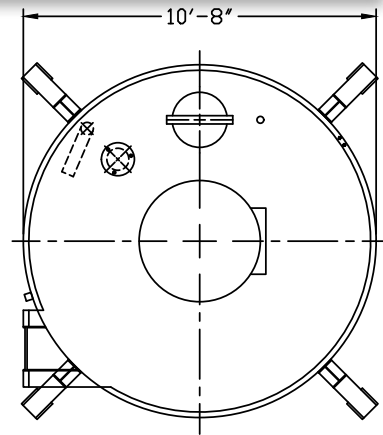

700 Barrel Basic Cement Silo

**BELGRADE
STEEL TANK**



700 Barrel Basic Cement Silo

- 12'-0" Diameter x 39'-8" Overall Height
- 150 Sq. Ft. Bag Area Dust Collector with Air Vibrator
- Pressure Relief Valve
- 3'-8" Clearance Under Discharge
- Outside Ladder with OSHA Compliant Fall Arrest Cable System
- 4" Fill Pipe with Aluminum Adapter
- 20" Non-Pressurized Inspection Manhole
- (8) Externally Mounted Air Pads with Manifold, Regulator, and Check Valve
- Emergency Jam Gate
- Sandblast, Prime, and Paint
- Standard Colors:
- RAL 7038 Gray, RAL 9010 White, RAL 1001 Tan, RAL 1032 Yellow

Options

- 225 Sq. Ft. Dust Collector
- 330 Sq. Ft. Pulse Jet Dust Collector
- Bin Level Indicators
- Manual Air Valve Controls
- Butterfly Valve
- 5" Fill Pipe

Specifications

- Empty Weight 15,000#
- 2,800 Cu. Ft. Capacity
- 130 Ton Capacity (Cement)
- Part Number: BST700-120

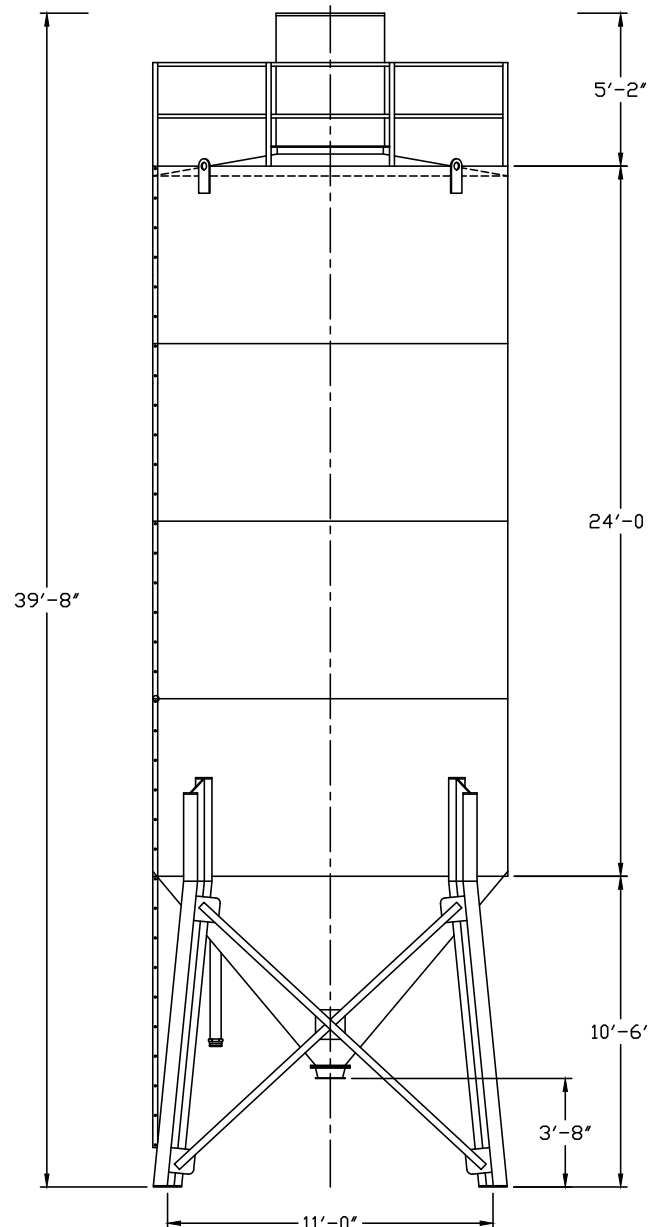
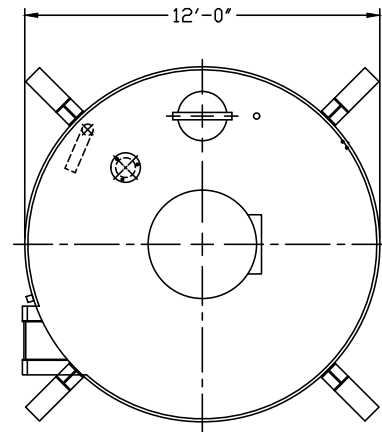

900 Barrel Basic Cement Silo

**BELGRADE
STEEL TANK**



900 Barrel Basic Cement Silo

- 12'-0" Diameter x 45'-8" Overall Height
- 150 Sq. Ft. Bag Area Dust Collector with Air Vibrator
- Pressure Relief Valve
- 3'-8" Clearance Under Discharge
- Outside Ladder with OSHA Compliant Fall Arrest Cable System
- 4" Fill Pipe with Aluminum Adapter
- 20" Non-Pressurized Inspection Manhole
- (8) Externally Mounted Air Pads with Manifold, Regulator, and Check Valve
- Emergency Jam Gate
- Sandblast, Prime, and Paint
- Standard Colors:
- RAL 7038 Gray, RAL 9010 White, RAL 1001 Tan, RAL 1032 Yellow

Options

- 225 Sq. Ft. Dust Collector
- 330 Sq. Ft. Pulse Jet Dust Collector
- Bin Level Indicators
- Manual Air Valve Controls
- Butterfly Valve
- 5" Fill Pipe

Specifications

- Empty Weight 17,000#
- 3,600 Cu. Ft. Capacity
- 168 Ton Capacity (Cement)
- Part Number: BST900-120

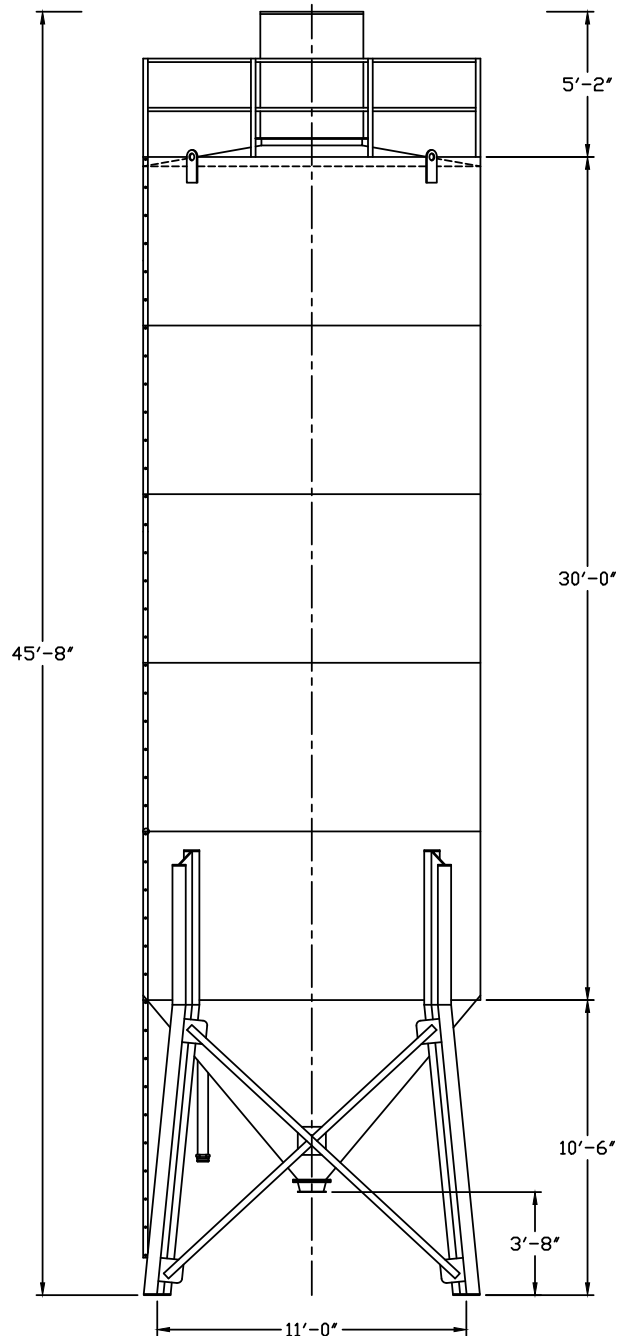
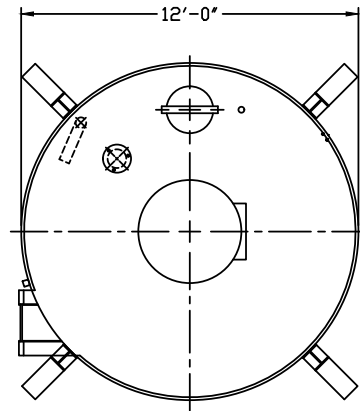

1050 Barrel Basic Cement Silo

BELGRADE
STEEL TANK



1050 Barrel Basic Cement Silo

- 12'-0" Diameter x 51'-8" Overall Height
- 150 Sq. Ft. Bag Area Dust Collector with Air Vibrator
- Pressure Relief Valve
- 3'-8" Clearance Under Discharge
- Outside Ladder with OSHA Compliant Fall Arrest Cable System
- 4" Fill Pipe with Aluminum Adapter
- 20" Non-Pressurized Inspection Manhole
- (8) Externally Mounted Air Pads with Manifold, Regulator, and Check Valve
- Emergency Jam Gate
- Sandblast, Prime, and Paint
- Standard Colors:
 - RAL 7038 Gray, RAL 9010 White, RAL 1001 Tan, RAL 1032 Yellow

Options

- 225 Sq. Ft. Dust Collector
- 330 Sq. Ft. Pulse Jet Dust Collector
- Bin Level Indicators
- Manual Air Valve Controls
- Butterfly Valve
- 5" Fill Pipe

Specifications

- Empty Weight 21,000#
- 4,200 Cu. Ft. Capacity
- 196 Ton Capacity (Cement)
- Part Number: BST1050-120

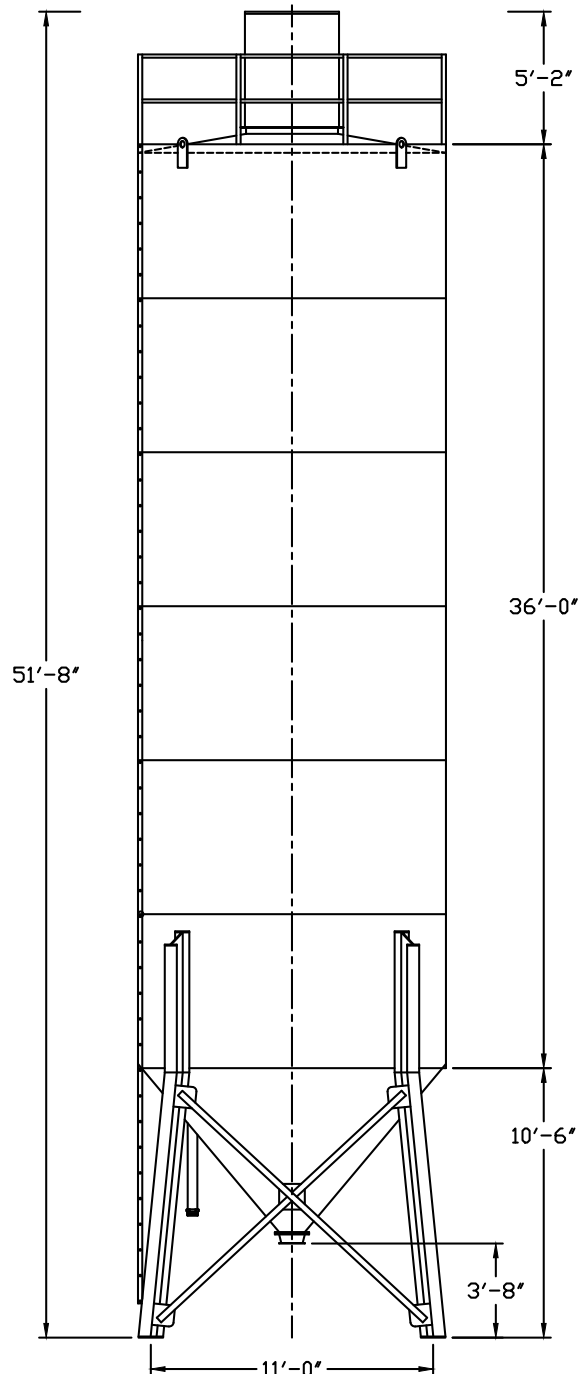
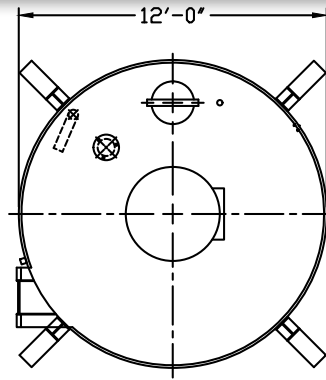

1200 Barrel Basic Cement Silo

**BELGRADE
STEEL TANK**



1200 Barrel Basic Cement Silo

- 12'-0" Diameter x 57'-8" Overall Height
- 150 Sq. Ft. Bag Area Dust Collector with Air Vibrator
- Pressure Relief Valve
- 3'-8" Clearance Under Discharge
- Outside Ladder with OSHA Compliant Fall Arrest Cable System
- 4" Fill Pipe with Aluminum Adapter
- 20" Non-Pressurized Inspection Manhole
- (8) Externally Mounted Air Pads with Manifold, Regulator, and Check Valve
- Emergency Jam Gate
- Sandblast, Prime, and Paint
- Standard Colors:
- RAL 7038 Gray, RAL 9010 White, RAL 1001 Tan, RAL 1032 Yellow

Options

- 225 Sq. Ft. Dust Collector
- 330 Sq. Ft. Pulse Jet Dust Collector
- Bin Level Indicators
- Manual Air Valve Controls
- Butterfly Valve
- 5" Fill Pipe

Specifications

- Empty Weight 24,000#
- 4,800 Cu. Ft. Capacity
- 225 Ton Capacity (Cement)
- Part Number: BST1200-120

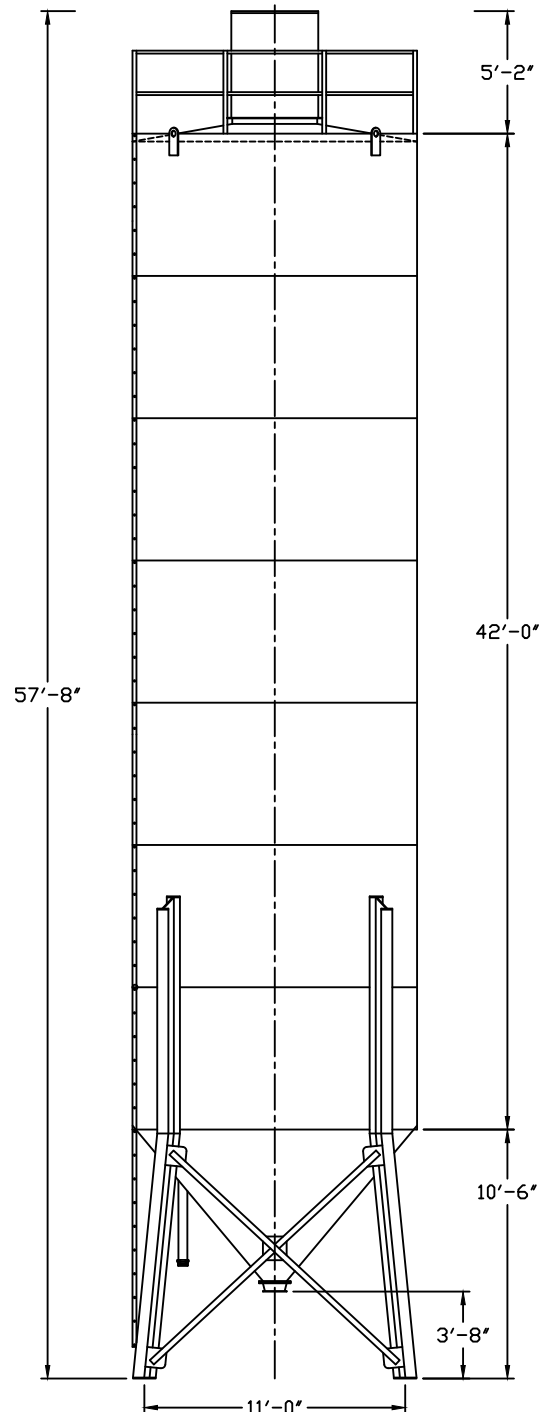
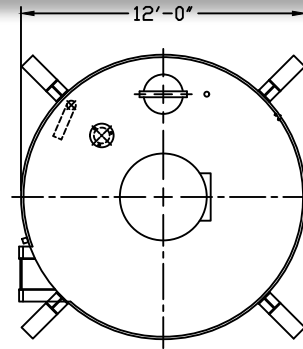

500 Barrel Split Cement Silo

**BELGRADE
STEEL TANK**



500 Barrel Split Silo

- 12'-0" Diameter x 33'-1" Overall Height
- (2) 150 Sq. Ft. Bag Area Dust Collectors with Air Vibrators
- (2) Pressure Relief Valves
- 3'-6" Clearance Under Discharge
- Outside Ladder with OSHA Compliant Fall Arrest Cable System
- (2) 4" Fill Pipes with Aluminum Adapters
- (2) 20" Non-Pressurized Inspection Manholes
- (12) Externally Mounted Air Pads with Manifold, Regulator, and Check Valve
- (2) Emergency Jam Gates
- Sandblast, Prime, and Paint
- Standard Colors:
 - RAL 7038 Gray, RAL 9010 White, RAL 1001 Tan, RAL 1032 Yellow

Options

- 225 Sq. Ft. Dust Collector
- 330 Sq. Ft. Pulse Jet Dust Collector
- Bin Level Indicators
- Manual Air Valve Controls
- Butterfly Valve
- 5" Fill Pipe
- 33/66 or 50/50 Split Design
- 2'-0" or 3'-6" Discharge Center

Specifications

- Empty Weight #18,000
- 2,000 Cu. Ft. Capacity
- 94 Ton Capacity (Cement)
- Part Number: BST500S-120

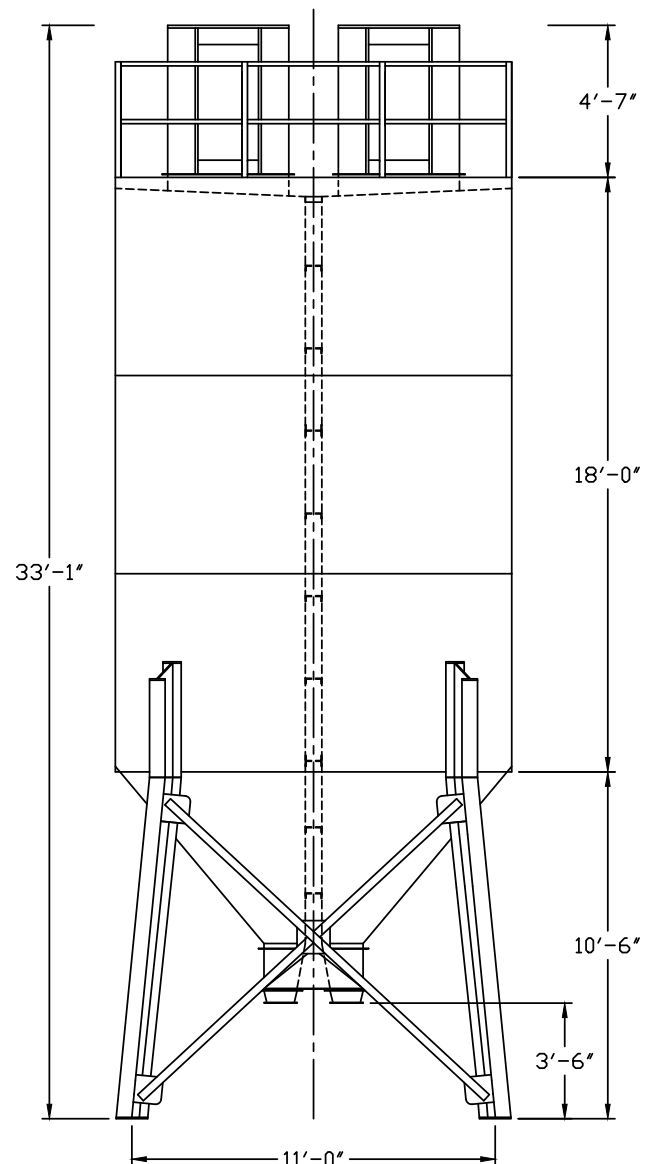
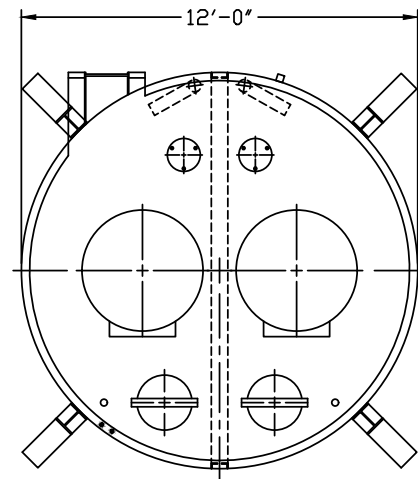

700 Barrel Split Cement Silo

**BELGRADE
STEEL TANK**



700 Barrel Split Silo

- 12'-0" Diameter x 39'-1" Overall Height
- (2) 150 Sq. Ft. Bag Area Dust Collectors with Air Vibrators
- (2) Pressure Relief Valves
- 3'-6" Clearance Under Discharge
- Outside Ladder with OSHA Compliant Fall Arrest Cable System
- (2) 4" Fill Pipes with Aluminum Adapters
- (2) 20" Non-Pressurized Inspection Manholes
- (12) Externally Mounted Air Pads with Manifold, Regulator, and Check Valve
- (2) Emergency Jam Gates
- Sandblast, Prime, and Paint
- Standard Colors: RAL 7038 Gray, RAL 9010 White, RAL 1001 Tan, RAL 1032 Yellow

Options

- 225 Sq. Ft. Dust Collector
- 330 Sq. Ft. Pulse Jet Dust Collector
- Bin Level Indicators
- Manual Air Valve Controls
- Butterfly Valve
- 5" Fill Pipe
- 33/66 or 50/50 Split Design
- 2'-0" or 3'-6" Discharge Center

Specifications

- Empty Weight 21,500#
- 2,600 Cu. Ft. Capacity
- 122 Ton Capacity (Cement)
- Part Number: BST700S-120

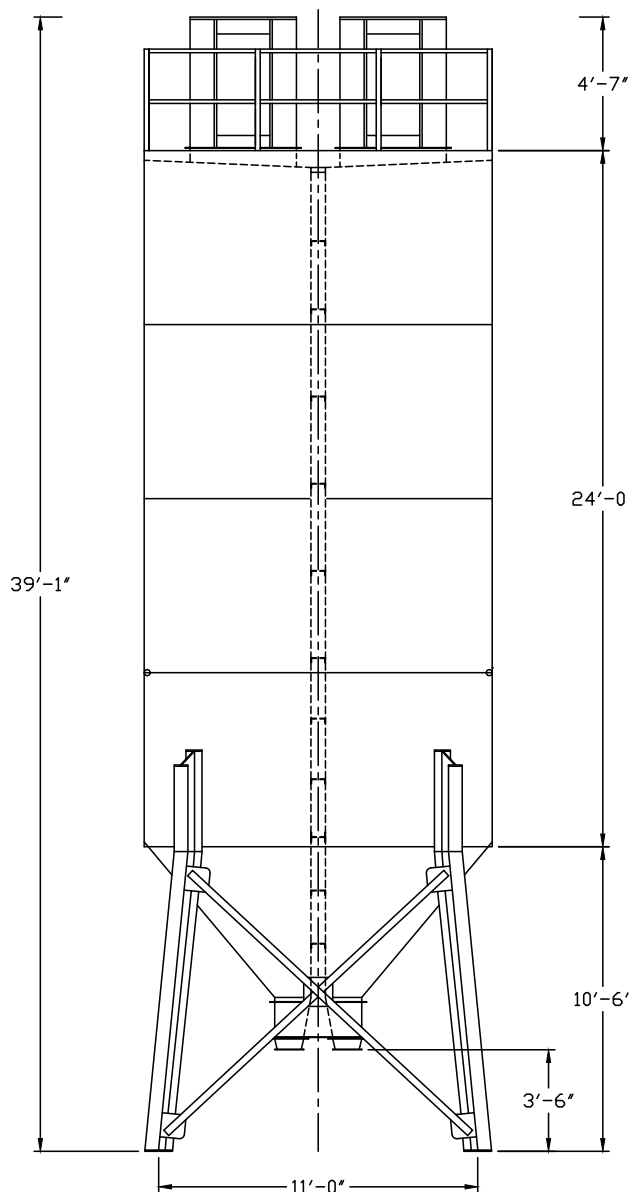
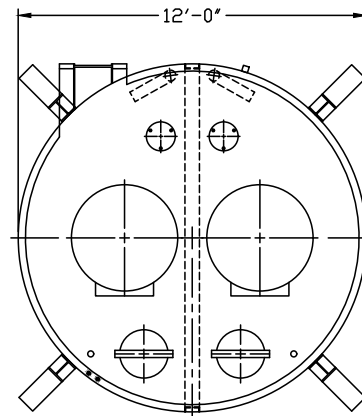

850 Barrel Split Cement Silo

**BELGRADE
STEEL TANK**



850 Barrel Split Silo

- 12'-0" Diameter x 45'-1" Overall Height
- (2) 150 Sq. Ft. Bag Area Dust Collectors with Air Vibrators
- (2) Pressure Relief Valves
- 3'-6" Clearance Under Discharge
- Outside Ladder with OSHA Compliant Fall Arrest Cable System
- (2) 4" Fill Pipes with Aluminum Adapters
- (2) 20" Non-Pressurized Inspection Manholes
- (12) Externally Mounted Air Pads with Manifold, Regulator, and Check Valve
- (2) Emergency Jam Gates
- Sandblast, Prime, and Paint
- Standard Colors:
- RAL 7038 Gray, RAL 9010 White, RAL 1001 Tan, RAL 1032 Yellow

Options

- 225 Sq. Ft. Dust Collector
- 330 Sq. Ft. Pulse Jet Dust Collector
- Bin Level Indicators
- Manual Air Valve Controls
- Butterfly Valve
- 5" Fill Pipe
- 33/66 or 50/50 Split Design
- 2'-0" or 3'-6" Discharge Center

Specifications

- Empty Weight 25,000#
- 3,400 Cu. Ft. Capacity
- 158 Ton Capacity (Cement)
- Part Number: BST850S-120

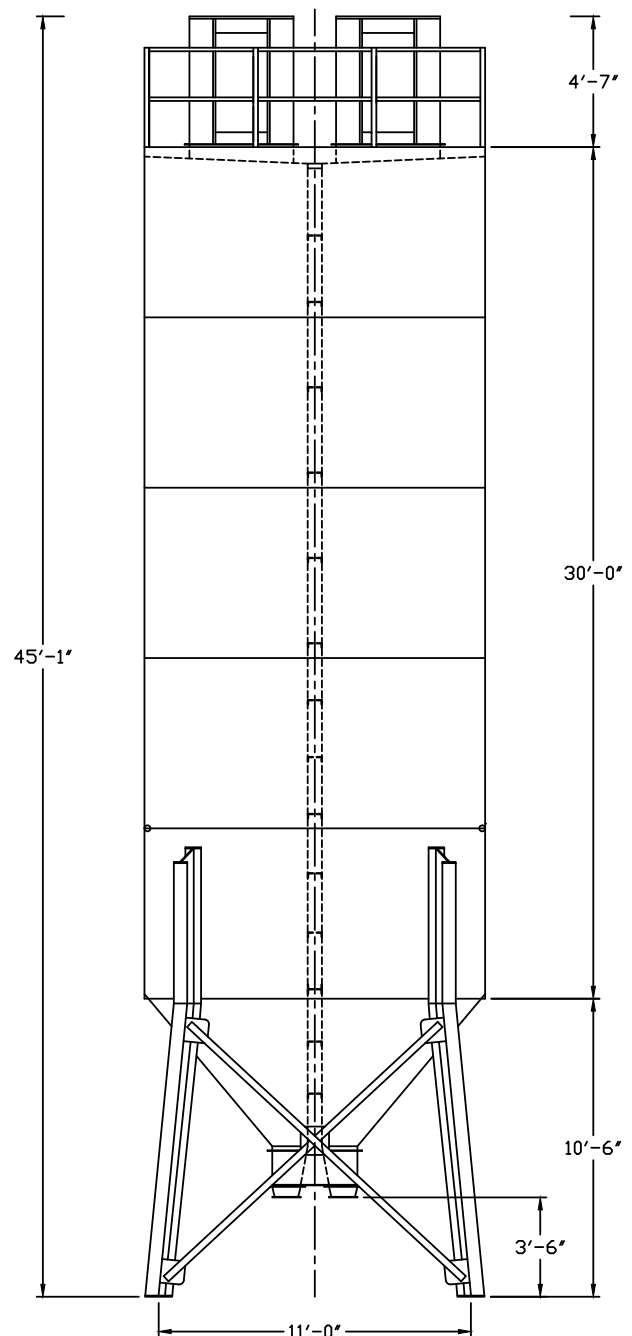
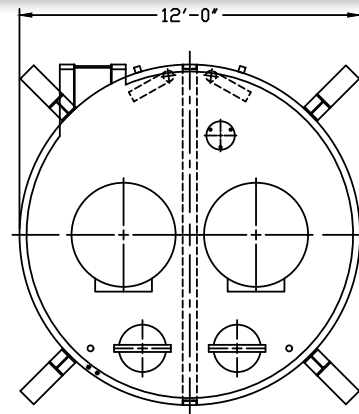

1000 Barrel Split Cement Silo

**BELGRADE
STEEL TANK**



1000 Barrel Split Silo

- 12'-0" Diameter x 51'-1" Overall Height
- (2) 150 Sq. Ft. Bag Area Dust Collectors with Air Vibrators
- (2) Pressure Relief Valves
- 3'-6" Clearance Under Discharge
- Outside Ladder with OSHA Compliant Fall Arrest Cable System
- (2) 4" Fill Pipes with Aluminum Adapters
- (2) 20" Non-Pressurized Inspection Manholes
- (12) Externally Mounted Air Pads with Manifold, Regulator, and Check Valve
- (2) Emergency Jam Gates
- Sandblast, Prime, and Paint
- Standard Colors:
 - RAL 7038 Gray, RAL 9010 White, RAL 1001 Tan, RAL 1032 Yellow

Options

- 225 Sq. Ft. Dust Collector
- 330 Sq. Ft. Pulse Jet Dust Collector
- Bin Level Indicators
- Manual Air Valve Controls
- Butterfly Valve
- 5" Fill Pipe
- 33/66 or 50/50 Split Design
- 2'-0" or 3'-6" Discharge Center

Specifications

- Empty Weight 30,000#
- 4,000 Cu. Ft. Capacity
- 187 Ton Capacity (Cement)
- Part Number: BST1000S-120

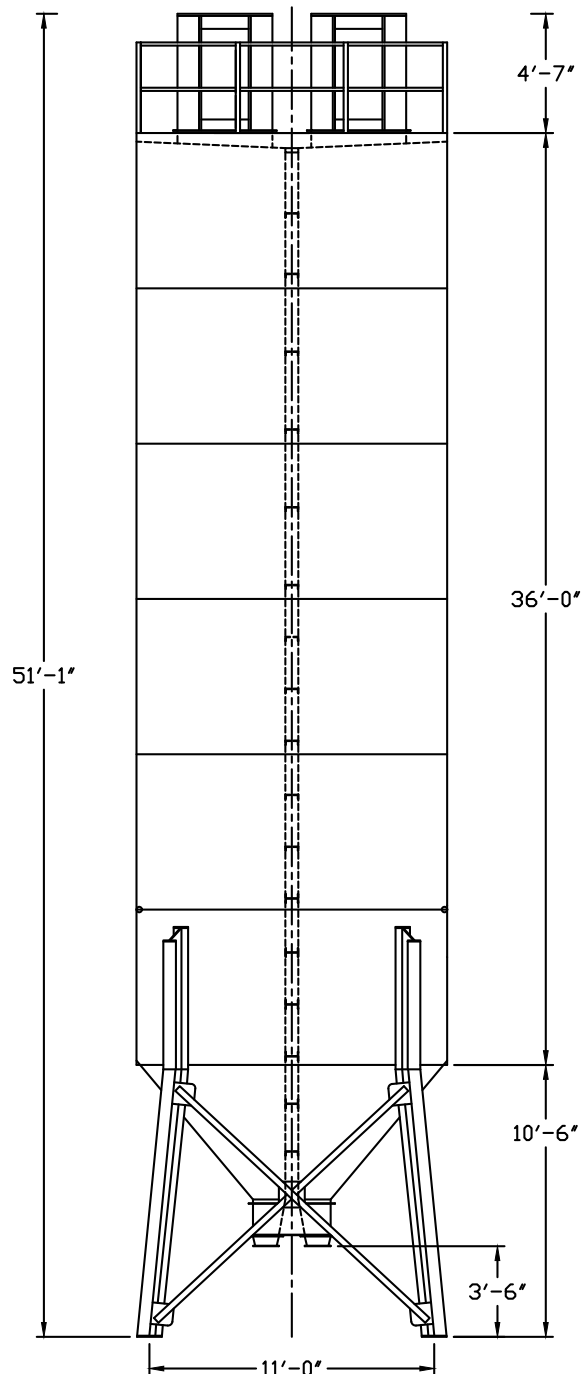
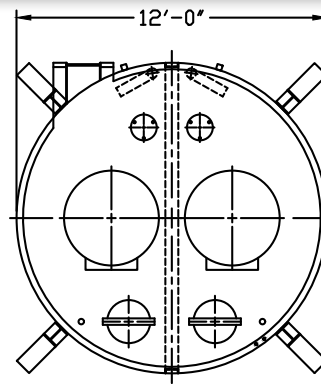

1200 Barrel Split Cement Silo

BELGRADE
STEEL TANK



1200 Barrel Split Silo

- 12'-0" Diameter x 57'-1" Overall Height
- (2) 150 Sq. Ft. Bag Area Dust Collectors with Air Vibrators
- (2) Pressure Relief Valves
- 3'-6" Clearance Under Discharge
- Outside Ladder with OSHA Compliant Fall Arrest Cable System
- (2) 4" Fill Pipes with Aluminum Adapters
- (2) 20" Non-Pressurized Inspection Manholes
- (12) Externally Mounted Air Pads with Manifold, Regulator, and Check Valve
- (2) Emergency Jam Gates
- Sandblast, Prime, and Paint
- Standard Colors:
 - RAL 7038 Gray, RAL 9010 White, RAL 1001 Tan, RAL 1032 Yellow

Options

- 225 Sq. Ft. Dust Collector
- 330 Sq. Ft. Pulse Jet Dust Collector
- Bin Level Indicators
- Manual Air Valve Controls
- Butterfly Valve
- 5" Fill Pipe
- 33/66 or 50/50 Split Design
- 2'-0" or 3'-6" Discharge Center

Specifications

- Empty Weight 35,000#
- 4,600 Cu. Ft. Capacity
- 213 Ton Capacity (Cement)
- Part Number: BST1200S-120

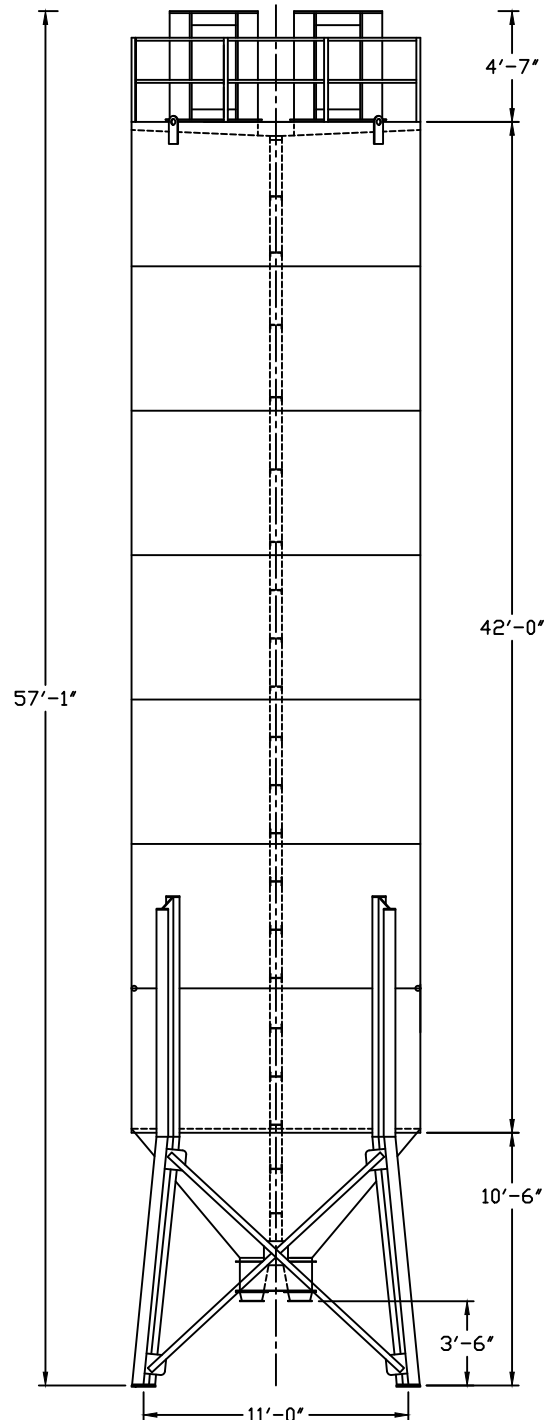
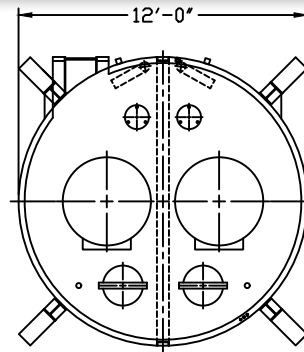

Belgrade Structural Stands

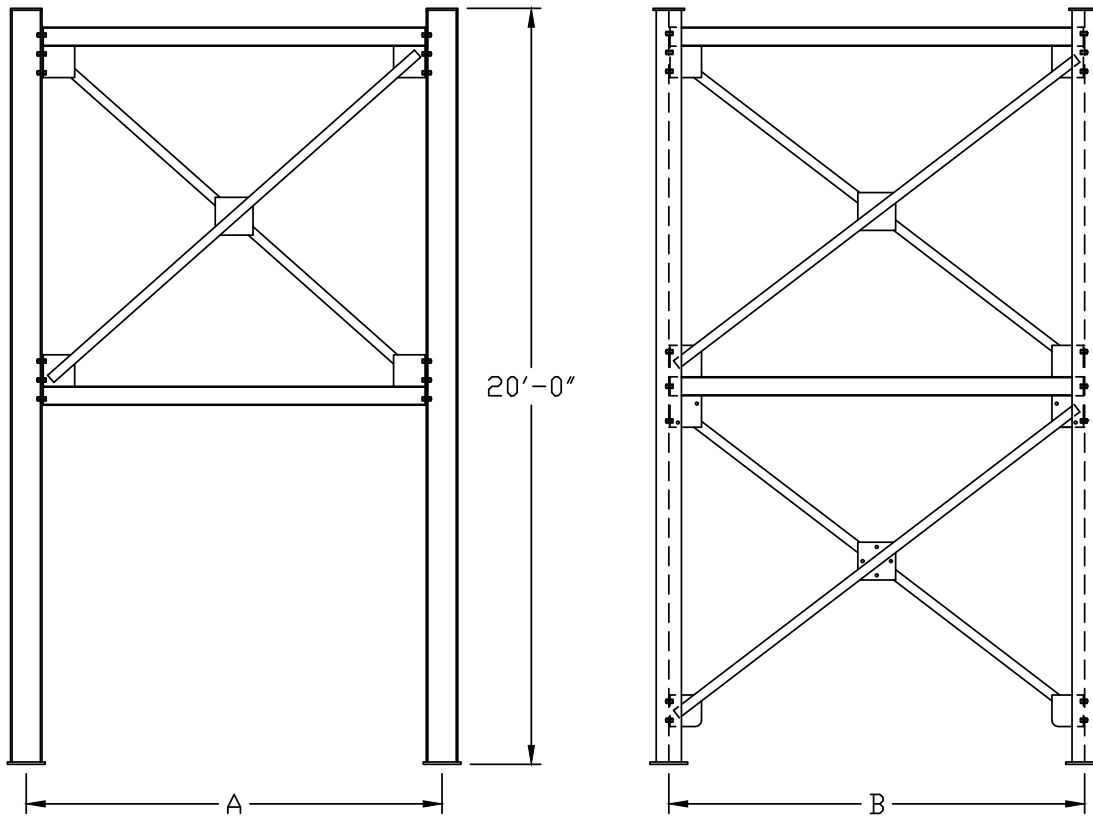

Non-Drive Thru Stands

- 20 Ft. Standard Height (Shorter or Taller May be Special Ordered)
- 4" Fill Pipe Extension
- Optional 5" Fill Pipe
- Outside Ladder with OSHA Compliant Fall Arrest Cable System
- Wide Flange Beam Columns and Horizontal Bracing with Angle Iron X-Bracing
- Minimal Bolted Assembly for Ease of Erection and Transportation
- Sandblast, Prime, and Paint
- Standard Colors:
- RAL 7038 Gray, RAL 9010 White, RAL 1001 Tan, RAL 1032 Yellow
- Optional Work Platform

Barrel	A	B	Weight
185	7'8"	7'8"	4,200#
270	7'8"	7'8"	4,200#
350	7'8"	7'8"	4,200#
450	9'10"	9'10"	4,200#
550	9'10"	9'10"	4,800#
700	11'0"	11'0"	4,800#
900	11'0"	11'0"	7,500#
1050	11'0"	11'0"	7,500#
1200	11'0"	11'0"	7,500#
700 Split	11'0"	11'0"	7,500#
850 Split	11'0"	11'0"	7,500#
1000 Split	11'0"	11'0"	7,500#
1200 Split	11'0"	11'0"	7,500#

Belgrade Structural Stands

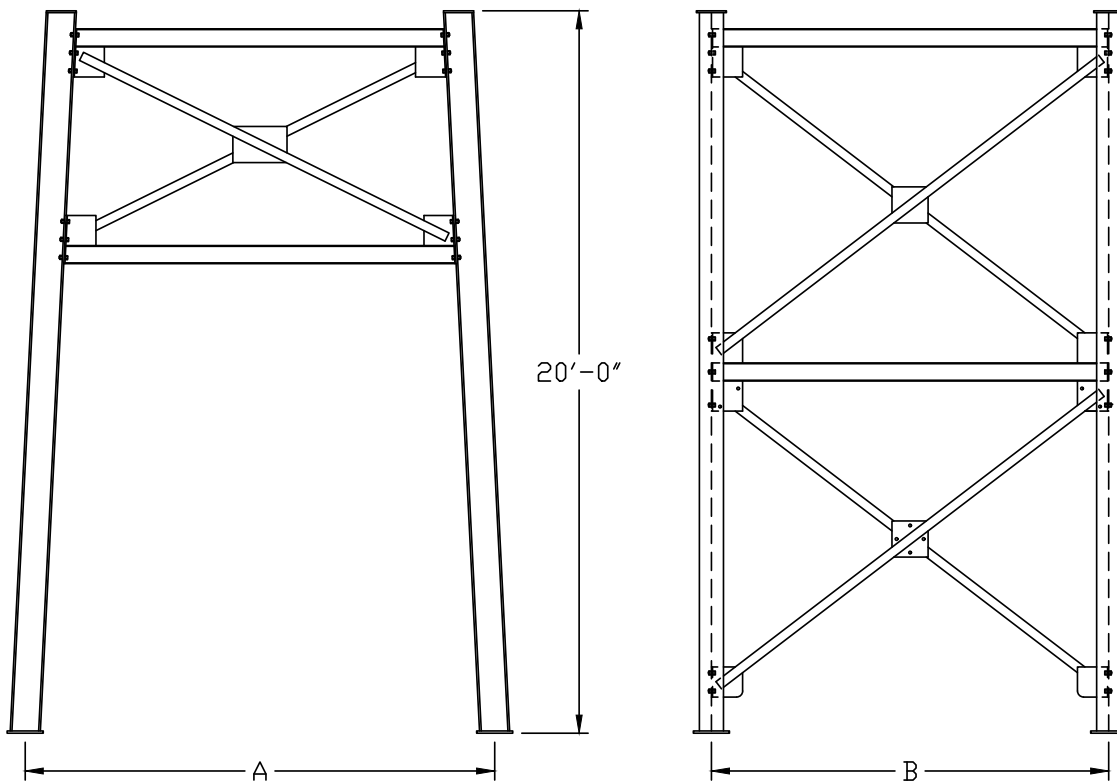

Drive Thru Stands

- 20 Ft. Standard Height (Shorter or Taller May be Special Ordered)
- 4" Fill Pipe Extension
Optional 5" Fill Pipe
- Outside Ladder with OSHA Compliant Fall Arrest Cable System
- Wide Flange Beam Columns and Horizontal Bracing with Angle Iron X-Bracing
- Minimal Bolted Assembly for Ease of Erection and Transportation
- Sandblast, Prime, and Paint
- Standard Colors:
- RAL 7038 Gray, RAL 9010 White, RAL 1001 Tan, RAL 1032 Yellow
- Optional Work Platform

Barrel	A	B	Weight
185	13'0"	7'8"	4,200#
270	13'0"	7'8"	4,200#
350	13'0"	7'8"	4,200#
450	13'0"	9'10"	4,200#
550	13'0"	9'10"	4,800#
700	13'0"	11'0"	4,800#
900	13'0"	11'0"	7,500#
1050	13'0"	11'0"	7,500#
1200	13'0"	11'0"	7,500#
700 Split	13'0"	11'0"	7,500#
850 Split	13'0"	11'0"	7,500#
1000 Split	13'0"	11'0"	7,500#
1200 Split	13'0"	11'0"	7,500#